



KILEREMSKIVER

Kileremskiver for taperbøsninger

Beskrivelse og specifikationer

Vore kileremskiver er fremstillet i henhold til international standard ISO 4183/DIN 2211.

Materiale

Støbejern EN-GJL-200(G20 – UNI 5007).

Overfladebehandling og afbalancering

Vore standard kileremskiver er rustbeskyttet ved fosfatering.

Alle skiver er statisk afbalanceret og kan anvendes ved periferihastigheder op til 35m/sek.

Beregning af periferihastighed (Vp):

$$V_p = \pi \cdot d_p \cdot n = \frac{d_p \cdot n}{60 \cdot 1000} = \frac{d_p \cdot n}{19100} \text{ m/sec}$$

Dp = diameter/mm

n = omdr/min

Vp = periferihastighed

Type	dp mm	α grader	b1 mm	br mm	e mm	f mm	c mm	t mm
SPZ (mm)	< 80 > 80	34° 38°	9,7	8,5	12	8	2	11
SPA (mm)	< 118 > 118	34° 38°	12,7	11	15	10	2,8	13,8
SPB (mm)	< 190 > 190	34° 38°	16,3	14	19	12,5	3,5	17,5
SPC (mm)	< 315 > 315	34° 38°	22,0	19	25,5	17	4,8	23,8

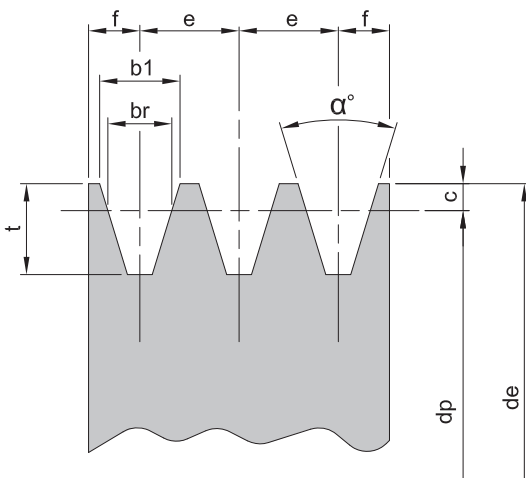

Kileremskiver for taperbøsninger

SPZ - 1

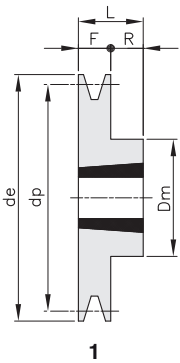

1

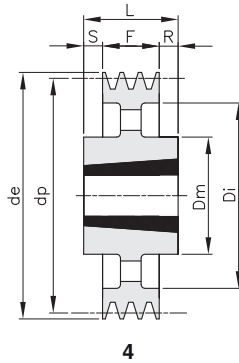

4

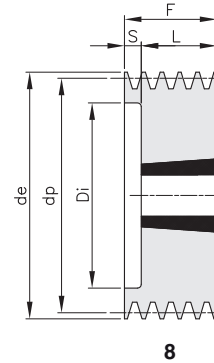

8

Materiale støbejern EN-GJL-200 / *Materiale stål

Betegnelse	Spor	dp	de	Type	Bøsning	Boring Max	Dm	Di	E	F	L	R	S	Kg.
*SPZ 50 01	1	50	54	8	1008	25		26		37	25		12	0,4
*SPZ 56 01	1	56	60	8	1008	25		32		37	25		12	0,5
*SPZ 60 01	1	60	64	1	1008	25				22	22			0,5
SPZ 63 01	1	63	67	1	1108	28	56			16	22	6		0,4
SPZ 67 01	1	67	71	1	1108	28	60			16	22	6		0,5
SPZ 71 01	1	71	75	1	1108	28	60			16	22	6		0,5
SPZ 75 01	1	75	79	1	1108	28	60			16	22	6		0,6
SPZ 80 01	1	80	84	1	1210	32	75			16	25	9		0,6
SPZ 85 01	1	85	89	1	1210	32	80			16	25	9		0,8
SPZ 90 01	1	90	94	1	1210	32	80			16	25	9		0,8
SPZ 95 01	1	95	99	1	1210	32	85			16	25	9		0,9
SPZ 100 01	1	100	104	1	1210	32	85			16	25	9		0,9
SPZ 106 01	1	106	110	1	1610	42	92			16	25	9		1,0
SPZ 112 01	1	112	116	1	1610	42	92			16	25	9		1,1
SPZ 118 01	1	118	122	1	1610	42	92			16	25	9		1,3
SPZ 125 01	1	125	129	1	1610	42	92			16	25	9		1,4
SPZ 132 01	1	132	136	1	1610	42	92			16	25	9		1,5
SPZ 140 01	1	140	144	1	1610	42	92			16	25	9		1,5
SPZ 150 01	1	150	154	1	1610	42	92			16	25	9		1,6
SPZ 160 01	1	160	164	1	1610	42	92			16	25	9		1,7
SPZ 170 01	1	170	174	1	1610	42	92			16	25	9		1,8
SPZ 180 01	1	180	184	4	1610	42	92	152		16	25	9		2,0
SPZ 190 01	1	190	194	4	1610	42	92	162		16	25	9		2,2
SPZ 200 01	1	200	204	4	2012	50	112	171		16	32	16		2,6
SPZ 224 01	1	224	228	4	2012	50	112	195		16	32	16		2,8
SPZ 250 01	1	250	254	4	2012	50	112	221		16	32	8	8	3,2
SPZ 280 01	1	280	284	4	2012	50	112	251		16	32	8	8	3,5
SPZ 315 01	1	315	319	4	2012	50	112	286		16	32	8	8	3,8
SPZ 355 01	1	355	359	4	2012	50	112	326		16	32	8	8	4,2
SPZ 400 01	1	400	404	4	2012	50	112	371		16	32	8	8	6,0
SPZ 450 01	1	450	454	4	2517	65	124	421		16	45	14,5	14,5	11,0

--	--	--	--	--	--	--	--	--	--	--	--	--	--	--

Kileremskiver for taperbøsninger

SPZ - 2

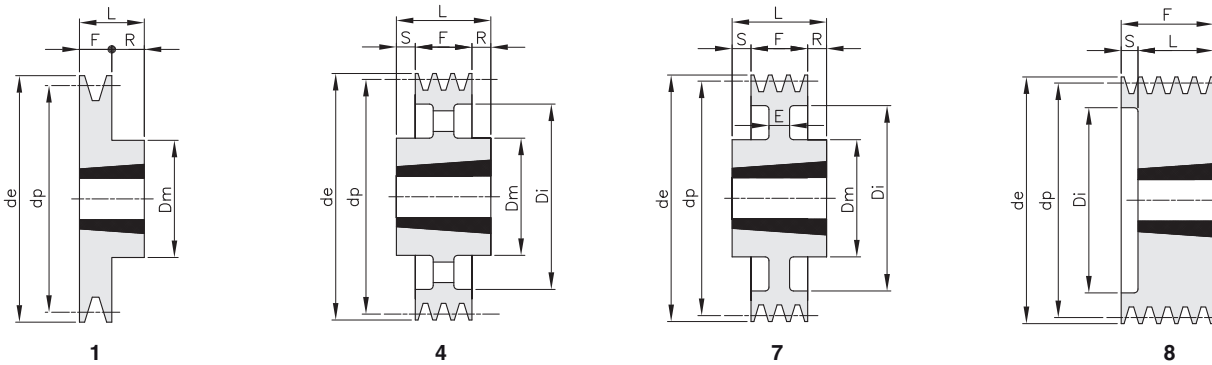

Materiale støbejern EN-GJL-200 / *Materiale stål

Betegnelse	Spor	dp	de	Type	Bøsning	Boring Max	Dm	Di	E	F	L	R	S	Kg.
*SPZ 50 02	2	50	54	8	1008	25		26		50	25		25	0,3
*SPZ 56 02	2	56	60	8	1008	25		32		49	22		27	0,6
SPZ 60 02	2	60	64	8	1108	28		36		49	22		27	0,6
SPZ 63 02	2	63	67	8	1108	28		40		28	22		6	0,5
SPZ 67 02	2	67	71	8	1108	28		42		28	22		6	0,5
SPZ 71 02	2	71	75	8	1108	28		42		28	22		6	0,5
SPZ 75 02	2	75	79	8	1210	32		51		28	25		3	0,6
SPZ 80 02	2	80	84	8	1210	32		51		28	25		3	0,7
SPZ 85 02	2	85	89	8	1610	42		60		28	25		3	0,7
SPZ 90 02	2	90	94	8	1610	42		61		28	25		3	0,8
SPZ 95 02	2	95	99	8	1610	42		66		28	25		3	0,8
SPZ 100 02	2	100	104	8	1610	42		71		28	25		3	1,2
SPZ 106 02	2	106	110	8	1610	42		76		28	25		3	1,2
SPZ 112 02	2	112	116	8	1610	42		83		28	25		3	1,3
SPZ 118 02	2	118	122	8	1610	42		90		28	25		3	1,4
SPZ 125 02	2	125	129	8	1610	42		96		28	25		3	1,7
SPZ 132 02	2	132	136	8	1610	42		103		28	25		3	2
SPZ 140 02	2	140	144	8	1610	42		111		28	25		3	2,2
SPZ 150 02	2	150	154	1	2012	50	112			28	32	4		2,3
SPZ 160 02	2	160	164	1	2012	50	112			28	32	4		2,5
SPZ 170 02	2	170	174	1	2012	50	112			28	32	4		2,6
SPZ 180 02	2	180	184	7	2012	50	112	152	10	28	32	4		2,9
SPZ 190 02	2	190	194	7	2012	50	112	162	10	28	32	4		3,3
SPZ 200 02	2	200	204	4	2012	50	112	171		28	32	4		3,5
SPZ 224 02	2	224	228	4	2012	50	112	195		28	32	4		3,7
SPZ 250 02	2	250	254	4	2012	50	112	221		28	32	2	2	3,9
SPZ 280 02	2	280	284	4	2012	50	112	251		28	32	2	2	4,9
SPZ 315 02	2	315	319	4	2012	50	112	286		28	32	2	2	5,8
SPZ 355 02	2	355	359	4	2012	50	112	326		28	32	2	2	6,3
SPZ 400 02	2	400	404	4	2517	65	124	371		28	45	8,5	8,5	7,1
SPZ 450 02	2	450	454	4	2517	65	124	421		28	45	8,5	8,5	9,4
SPZ 500 02	2	500	504	4	2517	65	124	471		28	45	8,5	8,5	10,5

Kileremskiver for taperbøsninger

SPZ - 3

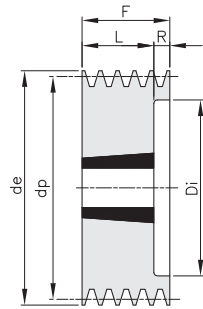

2

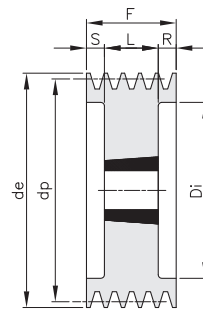

3

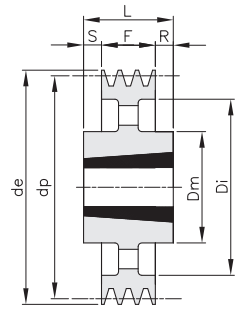

4

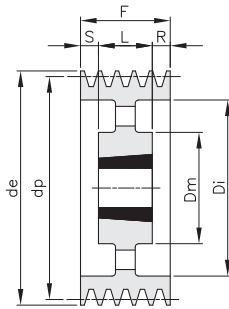

5

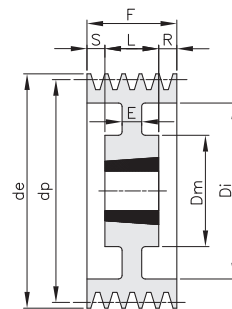

6

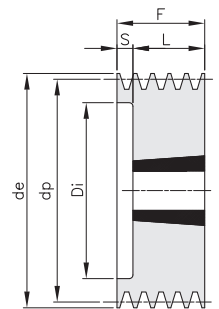

8

Materiale støbejern EN-GJL-200 / *Materiale stål

Betegnelse	Spør	dp	de	Type	Bøsning	Boring Max	Dm	Di	E	F	L	R	S	Kg.
SPZ 63 03	3	63	67	8	1108	28		40		40	22		18	0,5
SPZ 67 03	3	67	71	8	1108	28		42		40	22		18	0,7
SPZ 71 03	3	71	75	8	1108	28		42		40	22		18	0,7
SPZ 75 03	3	75	79	8	1210	32		51		40	25		15	0,8
SPZ 80 03	3	80	84	8	1210	32		51		40	25		15	0,8
SPZ 85 03	3	85	89	8	1610	42		60		40	25		15	0,8
SPZ 90 03	3	90	94	8	1610	42		61		40	25		15	0,9
SPZ 95 03	3	95	99	8	1610	42		66		40	25		15	1,1
SPZ 100 03	3	100	104	8	1610	42		71		40	25		15	1,2
SPZ 106 03	3	106	110	8	1610	42		76		40	25		15	1,4
SPZ 112 03	3	112	116	8	2012	50		83		40	32		8	1,5
SPZ 118 03	3	118	122	8	2012	50		90		40	32		8	1,6
SPZ 125 03	3	125	129	2	2012	50		96		40	32	8		2,0
SPZ 132 03	3	132	136	2	2012	50		103		40	32	8		2,4
SPZ 140 03	3	140	144	2	2010	50		111		40	32	8		2,8
SPZ 150 03	3	150	154	2	2012	50		121		40	32	8		3,4
SPZ 160 03	3	160	164	2	2012	50		131		40	32	8		3,6
SPZ 170 03	3	170	174	3	2012	50		141		40	32	4	4	3,7
SPZ 180 03	3	180	184	6	2012	50	106	151	7	40	32	8		3,7
SPZ 190 03	3	190	194	6	2012	50	112	161	10	40	32	4	4	4,0
SPZ 200 03	3	200	204	5	2012	50	112	171		40	32	4	4	4,3
SPZ 224 03	3	224	228	5	2012	50	112	195		40	32	4	4	4,7
SPZ 250 03	3	250	254	5	2012	50	112	221		40	32	4	4	5,4
SPZ 280 03	3	280	284	4	2517	65	124	251		40	45	2,5	2,5	6,5
SPZ 315 03	3	315	319	4	2517	65	124	286		40	45	2,5	2,5	7,8
SPZ 355 03	3	355	359	4	2517	65	124	326		40	45	2,5	2,5	8,9
SPZ 400 03	3	400	404	4	2517	65	124	371		40	45	2,5	2,5	9,1
SPZ 450 03	3	450	454	4	2517	65	124	421		40	45	2,5	2,5	9,7
SPZ 500 03	3	500	504	4	2517	65	124	471		40	45	2,5	2,5	10,6
SPZ 630 03	3	630	634	4	3020	75	150	601		40	51	5,5	5,5	15,0
SPZ 800 03	3	800	804	4	3020	75	150	771		40	51	5,5	5,5	28,5

--	--	--	--	--	--	--	--	--	--	--	--	--	--	--

Kileremskiver for taperbøsninger

SPZ - 4

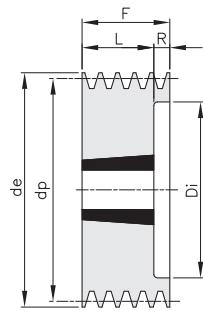

2

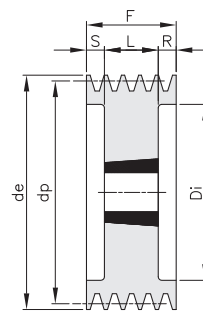

3

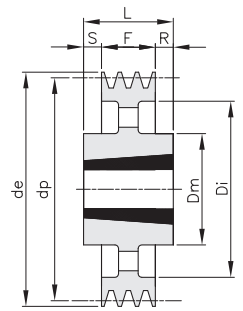

4

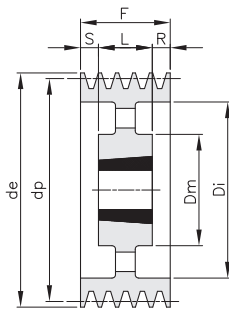

5

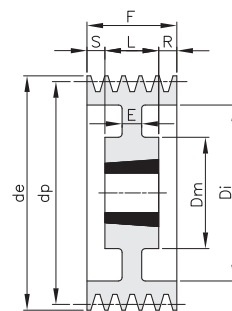

6

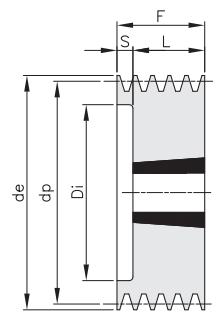

8

Materiale støbejern EN-GJL-200 / *Materiale stål

Betegnelse	Spør	dp	de	Type	Bøsning	Boring Max	Dm	Di	E	F	L	R	S	Kg.
SPZ 80 04	4	80	84	8	1210	32		51		52	25		27	0,9
SPZ 85 04	4	85	89	8	1610	42		60		52	25		27	1,0
SPZ 90 04	4	90	94	8	1610	42		61		52	25		27	1,1
SPZ 95 04	4	95	99	8	1610	42		66		52	25		27	1,2
SPZ 100 04	4	100	104	8	1610	42		71		52	25		27	1,3
SPZ 106 04	4	106	110	8	1610	42		76		52	25		27	1,4
SPZ 112 04	4	112	116	8	2012	50		83		52	32		20	1,6
SPZ 118 04	4	118	122	8	2012	50		90		52	32		20	1,9
SPZ 125 04	4	125	129	2	2012	50		96		52	32	20		2,2
SPZ 132 04	4	132	136	2	2012	50		103		52	32	20		2,6
SPZ 140 04	4	140	144	2	2012	50		111		52	32	20		3,0
SPZ 150 04	4	150	154	2	2517	65		121		52	45	7		3,6
SPZ 160 04	4	160	164	2	2517	65		131		52	45	7		4,5
SPZ 170 04	4	170	174	2	2517	65		141		52	45	7		4,8
SPZ 180 04	4	180	184	2	2517	65		151		52	45	7		5,0
SPZ 190 04	4	190	194	3	2517	65		161		52	45	3,5	3,5	5,1
SPZ 200 04	4	200	204	6	2517	65	124	171	8	52	45	3,5	3,5	5,2
SPZ 224 04	4	224	228	5	2517	65	124	195		52	45	3,5	3,5	5,9
SPZ 250 04	4	250	254	5	2517	65	124	221		52	45	3,5	3,5	6,6
SPZ 280 04	4	280	284	5	2517	65	124	251		52	45	3,5	3,5	7,2
SPZ 315 04	4	315	319	5	2517	65	124	286		52	45	3,5	3,5	8,5
SPZ 355 04	4	355	359	5	2517	65	124	326		52	45	3,5	3,5	9,4
SPZ 400 04	4	400	404	5	2517	65	124	371		52	45	3,5	3,5	11,2
SPZ 450 04	4	450	454	5	3020	75	146	421		52	45	0,5	0,5	11,6
SPZ 500 04	4	500	504	5	3020	75	146	471		52	51	0,5	0,5	12,4
SPZ 630 04	4	630	634	4	3030	75	146	601		52	76	12	12	18,0
SPZ 800 04	4	800	804	4	3030	75	146	771		52	76	12	12	38,0

Kileremskiver for taperbøsninger

SPZ - 5

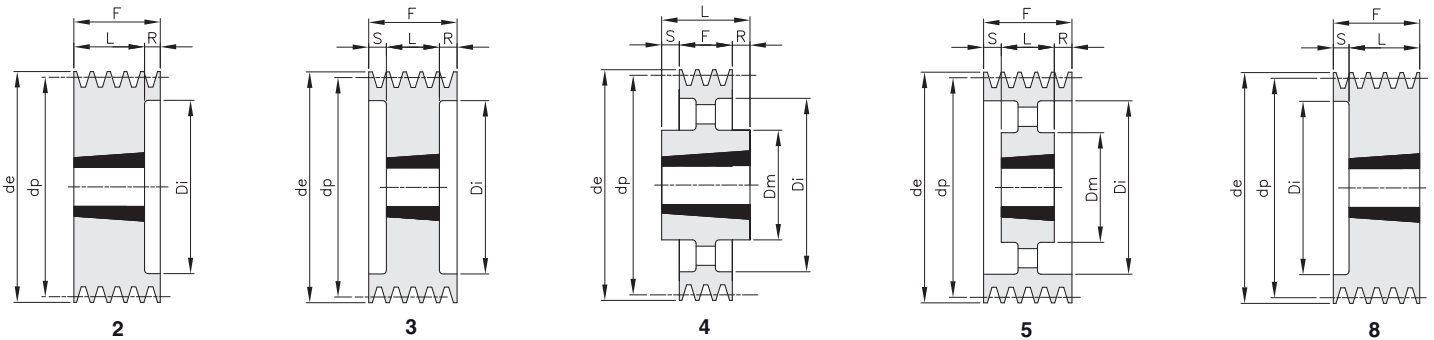

Materiale støbejern EN-GJL-200 / *Materiale stål

Betegnelse	Spor	dp	de	Type	Bøsning	Boring Max	Dm	Di	E	F	L	R	S	Kg.
SPZ 85 05	5	85	89	8	1610	42		60		64	25		39	1,2
SPZ 90 05	5	90	94	8	1610	42		61		64	25		39	1,4
SPZ 95 05	5	95	99	8	1610	42		66		64	25		39	1,5
SPZ 100 05	5	100	104	8	2012	50		71		64	32		32	1,6
SPZ 106 05	5	106	110	8	2012	50		76		64	32		32	1,8
SPZ 112 05	5	112	116	8	2012	50		83		64	32		32	1,9
SPZ 118 05	5	118	122	8	2012	50		90		64	32		32	2,4
SPZ 125 05	5	125	129	8	2012	50		96		64	32		32	2,8
SPZ 132 05	5	132	136	8	2517	65		103		64	45		19	2,8
SPZ 140 05	5	140	144	2	2517	65		111		64	45	19		3,2
SPZ 150 05	5	150	154	2	2517	65		121		64	45	19		3,9
SPZ 160 05	5	160	164	2	2517	65		131		64	45	19		4,7
SPZ 170 05	5	170	174	2	2517	65		141		64	45	19		5,5
SPZ 180 05	5	180	184	2	2517	65		151		64	45	19		6,2
SPZ 190 05	5	190	194	3	2517	65		161		64	45	9,5	9,5	6,4
SPZ 200 05	5	200	204	3	2517	65		171		64	45	9,5	9,5	6,5
SPZ 224 05	5	224	228	5	2517	65	124	195		64	45	9,5	9,5	7,2
SPZ 250 05	5	250	254	5	2517	65	124	221		64	45	9,5	9,5	7,6
SPZ 280 05	5	280	284	5	2517	65	124	251		64	45	9,5	9,5	9,0
SPZ 315 05	5	315	319	5	2517	65	124	286		64	45	9,5	9,5	10,0
SPZ 355 05	5	355	359	5	2517	65	124	326		64	45	9,5	9,5	12,1
SPZ 400 05	5	400	404	5	3020	75	146	371		64	51	6,5	6,5	13,8
SPZ 450 05	5	450	454	5	3020	75	146	421		64	51	6,5	6,5	16,0
SPZ 500 05	5	500	504	4	3030	75	146	471		64	76	6	6	20,5
SPZ 630 05	5	630	634	4	3030	75	146	601		64	76	6	6	27,6
SPZ 800 05	5	800	804	4	3535	90	178	771		64	89	12,5	12,5	44,0

Kileremskiver for taperbøsninger

SPZ - 6

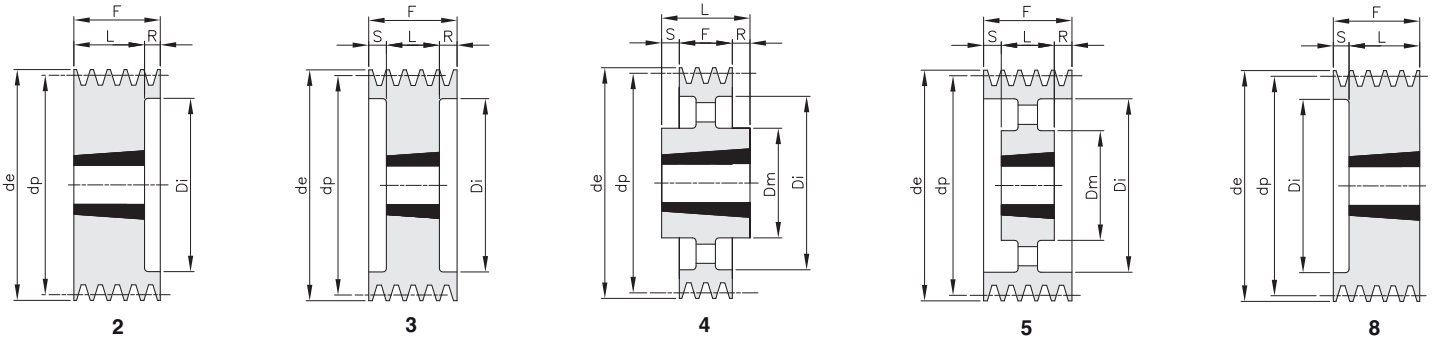

Materiale støbejern EN-GJL-200 / *Materiale stål

Betegnelse	Spor	dp	de	Type	Bøsning	Boring Max	Dm	Di	E	F	L	R	S	Kg.
SPZ 90 06	6	90	94	8	1610	42		61		76	25		51	1,5
SPZ 95 06	6	95	99	8	1610	42		66		76	25		51	1,7
SPZ 100 06	6	100	104	8	2012	50		71		76	32		44	1,8
SPZ 106 06	6	106	110	8	2012	50		76		76	32		44	2,0
SPZ 112 06	6	112	116	8	2012	50		83		76	32		44	2,2
SPZ 118 06	6	118	122	8	2517	65		90		76	45		31	2,4
SPZ 125 06	6	125	129	8	2517	65		96		76	45		31	2,9
SPZ 132 06	6	132	136	8	2517	65		103		76	45		31	3,2
SPZ 140 06	6	140	144	2	2517	65		111		76	45	31		3,5
SPZ 150 06	6	150	154	2	2517	65		121		76	45	31		4,5
SPZ 160 06	6	160	164	2	2517	65		131		76	45	31		5,5
SPZ 170 06	6	170	174	2	2517	65		141		76	45	31		6,5
SPZ 180 06	6	180	184	3	2517	65		151		76	45	15,5	15,5	6,5
SPZ 190 06	6	190	194	3	2517	65		161		76	45	15,5	15,5	6,4
SPZ 200 06	6	200	204	3	2517	65		171		76	45	15,5	15,5	6,2
SPZ 224 06	6	224	228	5	2517	65	124	195		76	45	15,5	15,5	7,1
SPZ 250 06	6	250	254	5	2517	65	124	221		76	45	15,5	15,5	8,3
SPZ 280 06	6	280	284	5	2517	65	124	251		76	45	15,5	15,5	9,9
SPZ 315 06	6	315	319	5	2517	65	124	286		76	45	15,5	15,5	11,5
SPZ 355 06	6	355	359	5	2517	65	124	326		76	45	15,5	15,5	14,0
SPZ 400 06	6	400	404	5	3030	75	146	371		76	76			17,6
SPZ 450 06	6	450	454	5	3030	75	146	421		76	76			21,6
SPZ 500 06	6	500	504	5	3030	75	146	471		76	76			23,0
SPZ 630 06	6	630	634	4	3535	90	175	601		76	89	6,5	6,5	33,0
SPZ 800 06	6	800	804	4	3535	90	178	771		76	89	6,5	6,5	52,0

Kileremskiver for taperbøsninger

SPZ - 8

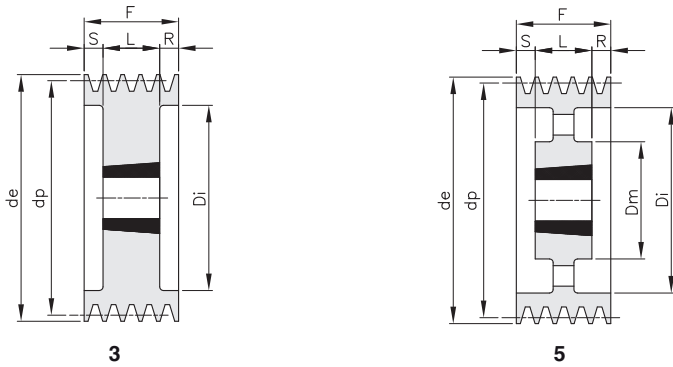

Materiale støbejern EN-GJL-200 / *Materiale stål

Betegnelse	Spor	dp	de	Type	Bøsning	Boring Max	Dm	Di	E	F	L	R	S	Kg.
SPZ 140 08	8	140	144	3	2517	65		111		100	45	27,5	27,5	4,0
SPZ 150 08	8	150	154	3	2517	65		121		100	45	27,5	27,5	5,1
SPZ 160 08	8	160	164	3	2517	65		131		100	45	27,5	27,5	5,6
SPZ 180 08	8	180	184	3	2517	65		151		100	45	27,5	27,5	7,1
SPZ 200 08	8	200	204	3	3020	75		171		100	51	24,5	24,5	9,3
SPZ 224 08	8	224	228	3	3020	75		195		100	51	24,5	24,5	11,8
SPZ 250 08	8	250	254	5	3020	75	146	221		100	51	24,5	24,5	10,5
SPZ 280 08	8	280	284	5	3020	75	146	251		100	51	24,5	24,5	10,8
SPZ 355 08	8	355	359	5	3030	75	146	326		100	76	12	12	16,0
SPZ 400 08	8	400	404	5	3030	75	146	371		100	76	12	12	18,2
SPZ 450 08	8	450	454	5	3535	90	175	421		100	89	5,5	5,5	24,0

Kileremskiver for taperbøsninger

SPA - 1

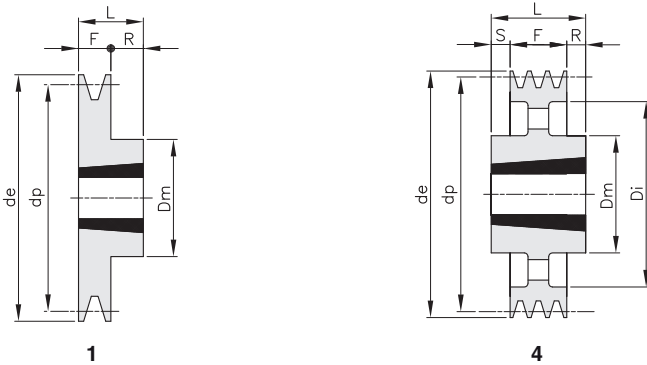

Materiale støbejern EN-GJL-200 / *Materiale stål

Betegnelse	Spor	dp	de	Type	Bøsning	Boring Max	Dm	Di	E	F	L	R	S	Kg.
SPA 63 01	1	63	68,5	1	1008	25	56			20	22	2		0,7
SPA 67 01	1	67	72,5	1	1108	28	56			20	22	2		0,5
SPA 71 01	1	71	76,5	1	1108	28	60			20	22	2		0,5
SPA 75 01	1	75	80,5	1	1108	28	60			20	22	2		0,6
SPA 80 01	1	80	85,5	1	1210	32	75			20	25	5		0,6
SPA 85 01	1	85	90,5	1	1210	32	80			20	25	5		0,7
SPA 90 01	1	90	95,5	1	1210	32	80			20	25	5		0,7
SPA 95 01	1	95	100,5	1	1210	32	85			20	25	5		0,8
SPA 100 01	1	100	105,5	1	1610	42	85			20	25	5		0,9
SPA 106 01	1	106	111,5	1	1610	42	92			20	25	5		1,0
SPA 112 01	1	112	117,5	1	1610	42	92			20	25	5		1,2
SPA 118 01	1	118	123,5	1	1610	42	92			20	25	5		1,3
SPA 125 01	1	125	130,5	1	1610	42	92			20	25	5		1,4
SPA 132 01	1	132	137,5	1	1610	42	92			20	25	5		1,5
SPA 140 01	1	140	145,5	1	1610	42	92			20	25	5		1,6
SPA 150 01	1	150	155,5	1	1610	42	92			20	25	5		1,7
SPA 160 01	1	160	165,5	1	1610	42	92			20	25	5		2,0
SPA 170 01	1	170	175,5	1	1610	42	92			20	25	5		1,8
SPA 180 01	1	180	185,5	4	1610	42	92	145		20	25	5		1,9
SPA 190 01	1	190	195,5	4	1610	42	92	156		20	25	5		2,5
SPA 200 01	1	200	205,5	4	2012	50	108	165		20	32	12		2,8
SPA 212 01	1	212	217,5	4	2012	50	110	177		20	32	12		2,9
SPA 224 01	1	224	229,5	4	2012	50	112	189		20	32	12		3,0
SPA 236 01	1	236	241,5	4	2012	50	112	202		20	32	12		3,2
SPA 250 01	1	250	255,5	4	2012	50	112	215		20	32	6	6	3,6
SPA 280 01	1	280	285,5	4	2012	50	112	245		20	32	12		4,2
SPA 300 01	1	300	305,5	4	2012	50	112	265		20	32	12		4,3
SPA 315 01	1	315	320,5	4	2012	50	112	280		20	32	12		5,2
SPA 355 01	1	355	360,5	4	2012	50	112	320		20	32	12		5,9
SPA 400 01	1	400	405,5	4	2012	50	112	365		20	32	12		6,3
SPA 450 01	1	450	455,5	4	2012	50	112	415		20	32	12		6,8
SPA 500 01	1	500	505,5	4	2517	65	124	465		20	45	25		8,3
SPA 630 01	1	630	635,5	4	2517	65	124	595		20	45	25		12,5

Kileremskiver for taperbøsninger

SPA - 2

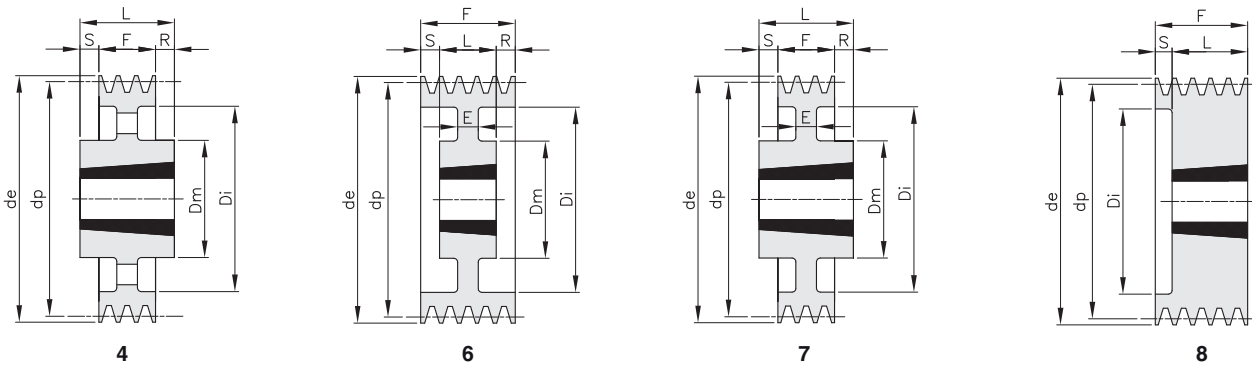

Materiale støbejern EN-GJL-200 / *Materiale stål

Betegnelse	Spor	dp	de	Type	Bøsning	Boring Max	Dm	Di	E	F	L	R	S	Kg.
*SPA 63 02	2	63	68,5	8	1008	25		32,5		35	22		13	0,5
SPA 67 02	2	67	72,5	8	1108	28		37		35	22		13	0,6
SPA 71 02	2	71	76,5	8	1108	28		40		35	22		13	0,6
SPA 75 02	2	75	80,5	8	1108	28		44		35	25		13	0,7
SPA 80 02	2	80	85,5	8	1210	32		50		35	25		10	0,7
SPA 85 02	2	85	90,5	8	1210	32		55		35	25		10	0,8
SPA 90 02	2	90	95,5	8	1610	42		59		35	25		10	0,9
SPA 95 02	2	95	100,5	8	1610	42		63		35	25		10	1,0
SPA 100 02	2	100	105,5	8	1610	42		66		35	25		10	1,0
SPA 106 02	2	106	111,5	8	1610	42		72		35	25		10	1,2
SPA 112 02	2	112	117,5	8	1610	42		78		35	25		10	1,4
SPA 118 02	2	118	123,5	8	1610	42		84		35	25		10	1,7
SPA 125 02	2	125	130,5	8	1610	42		91		35	25		10	1,9
SPA 132 02	2	132	137,5	8	2012	50		98		35	32		3	2,1
SPA 140 02	2	140	145,5	8	2012	50		106		35	32		3	2,6
SPA 150 02	2	150	155,5	8	2012	50		116		35	32		3	3,2
SPA 160 02	2	160	165,5	8	2012	50		125		35	32		3	3,6
SPA 170 02	2	170	175,5	8	2012	50		135		35	32		3	4,0
SPA 180 02	2	180	185,5	6	2012	50	108	146	10	35	32	1,5	1,5	5,0
SPA 190 02	2	190	195,5	6	2012	50	108	156	10	35	32	1,5	1,5	4,4
SPA 200 02	2	200	205,5	7	2517	65	123	163	10	35	45	5	5	4,5
SPA 212 02	2	212	217,5	4	2517	65	123	177		35	45	5	5	4,7
SPA 224 02	2	224	229,5	4	2517	65	124	189		35	45	10		5,0
SPA 236 02	2	236	241,5	4	2517	65	124	202		35	45	10		5,4
SPA 250 02	2	250	255,5	4	2517	65	124	215		35	45	5	5	5,6
SPA 280 02	2	280	285,5	4	2517	65	124	245		35	45	10		6,2
SPA 300 02	2	300	305,5	4	2517	65	124	265		35	45	10		6,8
SPA 315 02	2	315	320,5	4	2517	65	124	280		35	45	10		7,2
SPA 355 02	2	355	360,5	4	2517	65	124	320		35	45	10		9,4
SPA 400 02	2	400	405,5	4	2517	65	124	365		35	45	10		10,0
SPA 450 02	2	450	455,5	4	2517	65	124	415		35	45	10		10,5
SPA 500 02	2	500	505,5	4	2517	65	124	465		35	45	10		11,0
SPA 630 02	2	630	635,5	4	3020	75	159	595		35	51	8	8	20,5

Kileremskiver for taperbøsninger

SPA - 3

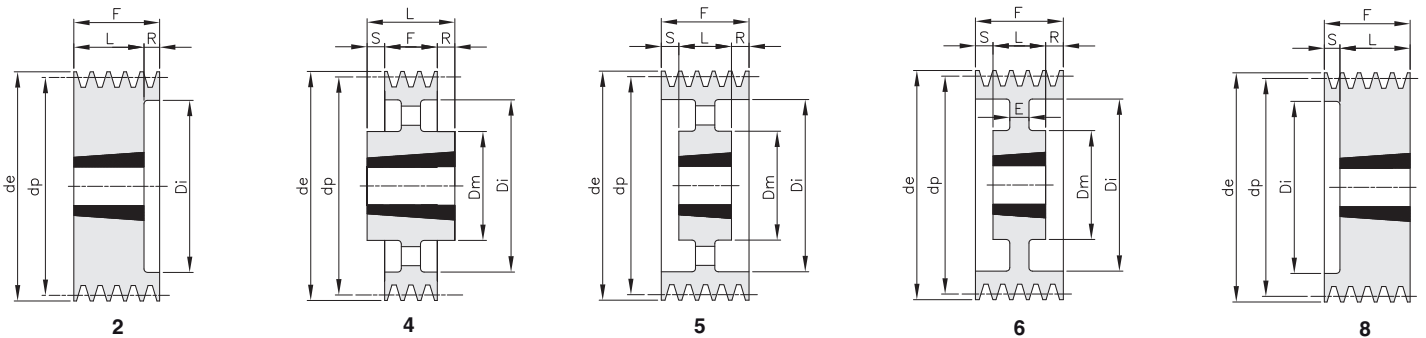

Materiale støbejern EN-GJL-200 / *Materiale stål

Betegnelse	Spor	dp	de	Type	Bøsning	Boring Max	Dm	Di	E	F	L	R	S	Kg.
SPA 71 03	3	71	76,5	8	1108	28		40		50	22		28	0,8
SPA 75 03	3	75	80,5	8	1108	28		44		50	22		28	0,9
SPA 80 03	3	80	85,5	8	1210	32		50		50	25		25	1,1
SPA 85 03	3	85	90,5	8	1210	32		55		50	25		25	1,2
SPA 90 03	3	90	95,5	8	1610	42		59		50	25		25	1,3
SPA 95 03	3	95	100,5	8	1610	42		63		50	25		25	1,5
SPA 100 03	3	100	105,5	2	1610	42		66		50	25	25		1,8
SPA 106 03	3	106	111,5	2	1610	42		72		50	25	25		2,1
SPA 112 03	3	112	117,5	8	2012	50		78		50	32		18	2,3
SPA 118 03	3	118	123,5	2	2012	50		84		50	32	18		2,5
SPA 125 03	3	125	130,5	2	2012	50		91		50	32	18		2,7
SPA 132 03	3	132	137,5	2	2012	50		98		50	32	18		2,9
SPA 140 03	3	140	145,5	8	2517	65		106		50	45		5	3,2
SPA 150 03	3	150	155,5	8	2517	65		116		50	45		5	3,5
SPA 160 03	3	160	165,5	8	2517	65		125		50	45		5	4,5
SPA 170 03	3	170	175,5	8	2517	65		135		50	45		5	5,0
SPA 180 03	3	180	185,5	8	2517	65		146		50	45		5	5,5
SPA 190 03	3	190	195,5	8	2517	65		156		50	45		5	6,3
SPA 200 03	3	200	205,5	6	2517	65	123	165	20	50	45	2,5	2,5	5,8
SPA 212 03	3	212	217,5	5	2517	65	123	177		50	45	2,5	2,5	6,0
SPA 224 03	3	224	229,5	5	2517	65	124	189		50	45	2,5	2,5	6,3
SPA 236 03	3	236	241,5	5	2517	65	124	202		50	45	2,5	2,5	6,6
SPA 250 03	3	250	255,5	5	2517	65	124	215		50	45	2,5	2,5	7,3
SPA 280 03	3	280	285,5	5	2517	65	124	245		50	45	2,5	2,5	8,0
SPA 300 03	3	300	305,5	4	3020	75	159	265		50	51	0,5	0,5	9,1
SPA 315 03	3	315	320,5	4	3020	75	159	280		50	51	0,5	0,5	9,4
SPA 355 03	3	355	360,5	4	3020	75	159	320		50	51	0,5	0,5	11,5
SPA 400 03	3	400	405,5	4	3020	75	159	365		50	51	1		13,3
SPA 450 03	3	450	455,5	4	3020	75	159	415		50	51	1		14,2
SPA 500 03	3	500	505,5	4	3020	75	159	465		50	51	1		16,1
SPA 560 03	3	560	565,5	4	3020	75	159	525		50	51	1		18,0
SPA 630 03	3	630	635,5	4	3020	75	159	595		50	51	1		20,0
SPA 800 03	3	800	805,5	4	3535	90	175	765		50	89	19,5	19,5	34,5
SPA1000 03	3	1000	1005,5	4	3535	90	175	965		50	89	19,5	19,5	49,3

Kileremskiver for taperbøsninger

SPA - 4

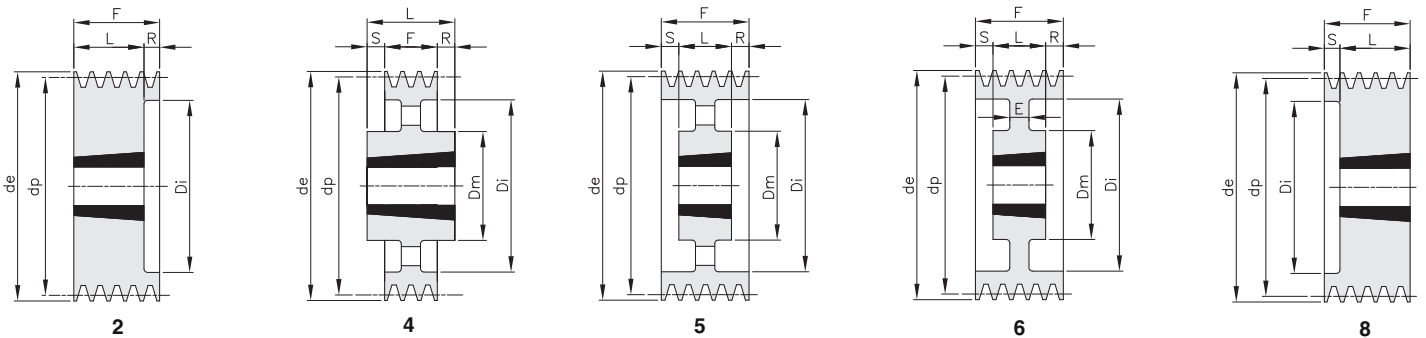

Materiale støbejern EN-GJL-200 / *Materiale stål

Betegnelse	Spor	dp	de	Type	Bøsning	Boring Max	Dm	Di	E	F	L	R	S	Kg.
SPA 90 04	4	90	95,5	8	1615	42		59		65	38		27	1,4
SPA 95 04	4	95	100,5	8	1615	42		63		65	38		27	1,6
SPA 100 04	4	100	105,5	2	1615	42		66		65	38	27		1,8
SPA 106 04	4	106	111,5	8	2012	50		72		65	32		33	2,1
SPA 112 04	4	112	117,5	8	2012	50		78		65	32		33	2,5
SPA 118 04	4	118	123,5	2	2012	50		84		65	32	33		2,8
SPA 125 04	4	125	130,5	2	2012	50		91		65	32	33		3,0
SPA 132 04	4	132	137,5	2	2517	65		98		65	45	20		3,2
SPA 140 04	4	140	145,5	2	2517	65		106		65	45	20		3,5
SPA 150 04	4	150	155,5	2	2517	65		116		65	45	20		3,9
SPA 160 04	4	160	165,5	2	2517	65		125		65	45	20		4,3
SPA 170 04	4	170	175,5	2	2517	65		135		65	45	20		5,8
SPA 180 04	4	180	185,5	2	2517	65		146		65	45	20		6,2
SPA 190 04	4	190	195,5	2	2517	65		156		65	45	20		6,8
SPA 200 04	4	200	205,5	2	3020	75		165		65	51	14		7,5
SPA 212 04	4	212	217,5	2	3020	75		177		65	51	14		8,4
SPA 224 04	4	224	229,5	2	3020	75		189		65	51	14		8,8
SPA 236 04	4	236	241,5	6	3020	75	159	202	20	65	51	14		9,8
SPA 250 04	4	250	255,5	5	3020	75	159	215		65	51	7	7	10,0
SPA 280 04	4	280	285,5	5	3020	75	159	245		65	51	7	7	11,5
SPA 300 04	4	300	305,5	5	3020	75	159	265		65	51	7	7	12,4
SPA 315 04	4	315	320,5	5	3020	75	159	280		65	51	7	7	12,9
SPA 355 04	4	355	360,5	5	3020	75	159	320		65	51	7	7	13,5
SPA 400 04	4	400	405,5	5	3020	75	159	365		65	51	7	7	14,0
SPA 450 04	4	450	455,5	5	3020	75	159	415		65	51	7	7	15,8
SPA 500 04	4	500	505,5	5	3020	75	159	465		65	51	7	7	18,7
SPA 560 04	4	560	565,5	4	3535	90	175	525		65	89	12	12	24,5
SPA 630 04	4	630	635,5	4	3535	90	175	595		65	89	12	12	30,0
SPA 800 04	4	800	805,5	4	3535	90	175	765		65	89	12	12	43,2
SPA1000 04	4	1000	1005,5	4	4040	100	210	965		65	102	18,5	18,5	69,0

Kileremskiver for taperbøsninger

SPA - 5

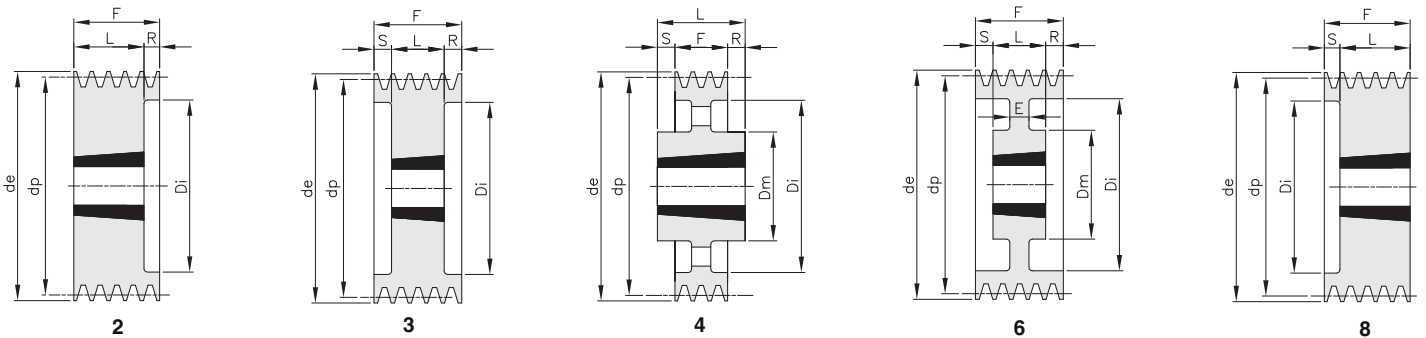

Materiale støbejern EN-GJL-200 / *Materiale stål

Betegnelse	Spor	dp	de	Type	Bøsning	Boring Max	Dm	Di	E	F	L	R	S	Kg.
SPA 100 05	5	100	105,5	2	1615	42		66		80	38	42		2,1
SPA 106 05	5	106	111,5	8	2012	50		72		80	32		48	2,3
SPA 112 05	5	112	117,5	8	2012	50		78		80	32		48	2,5
SPA 118 05	5	118	123,5	2	2012	50		84		80	32	48		2,8
SPA 125 05	5	125	130,5	3	2012	50		91		80	32	24	24	3,0
SPA 132 05	5	132	137,5	3	2517	65		98		80	45	17,5	17,5	3,5
SPA 140 05	5	140	145,5	3	2517	65		106		80	45	17,5	17,5	3,9
SPA 150 05	5	150	155,5	3	2517	65		116		80	45	17,5	17,5	4,4
SPA 160 05	5	160	165,5	3	2517	65		125		80	45	17,5	17,5	5,7
SPA 170 05	5	170	175,5	3	2517	65		135		80	45	17,5	17,5	6,3
SPA 180 05	5	180	185,5	3	3020	75		146		80	51	14,5	14,5	6,9
SPA 190 05	5	190	195,5	2	3020	75		156		80	51	29		7,7
SPA 200 05	5	200	205,5	3	3020	75		168		80	51	14,5	14,5	9,0
SPA 212 05	5	212	217,5	2	3020	75		177		80	51	29		9,8
SPA 224 05	5	224	229,5	2	3020	75		189		80	51	29		10,2
SPA 236 05	5	236	241,5	2	3020	75		202		80	51	29		11,2
SPA 250 05	5	250	255,5	6	3020	75	159	215	20	80	51	14,5	14,5	12,4
SPA 280 05	5	280	285,5	4	3535	90	175	245		80	89	4,5	4,5	15,0
SPA 300 05	5	300	305,5	4	3535	90	175	265		80	89	4,5	4,5	16,5
SPA 315 05	5	315	320,5	4	3535	90	175	280		80	89	4,5	4,5	18,1
SPA 355 05	5	355	360,5	4	3535	90	175	320		80	89	4,5	4,5	19,2
SPA 400 05	5	400	405,5	4	3535	90	175	365		80	89	4,5	4,5	21,5
SPA 450 05	5	450	455,5	4	3535	90	175	415		80	89	4,5	4,5	23,0
SPA 500 05	5	500	505,5	4	3535	90	175	465		80	89	4,5	4,5	26,5
SPA 560 05	5	560	565,5	4	3535	90	175	525		80	89	4,5	4,5	30,0
SPA 630 05	5	630	635,5	4	3535	90	175	595		80	89	4,5	4,5	34,5
SPA 800 05	5	800	805,5	4	4040	100	210	765		80	102	11	11	55,5
SPA1000 05	5	1000	1005,5	4	4545	110	242	965		80	114	17	17	80,0

Kileremskiver for taperbøsninger

SPA - 6

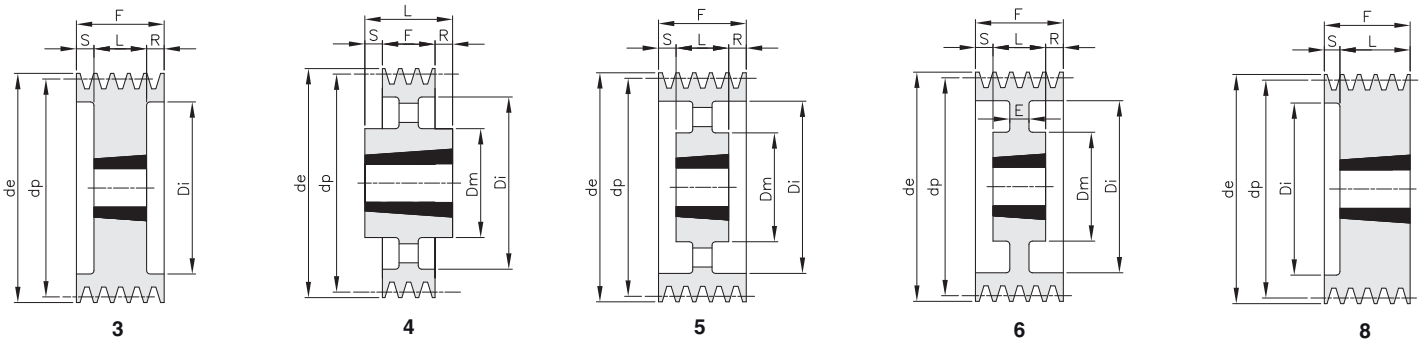

Materiale støbejern EN-GJL-200 / *Materiale stål

Betegnelse	Spor	dp	de	Type	Bøsning	Boring Max	Dm	Di	E	F	L	R	S	Kg.
SPA 100 06	6	100	105,5	3	1610	42		66		95	25	40	30	2,5
SPA 106 06	6	106	111,5	8	2012	50		72		95	32		63	2,6
SPA 112 06	6	112	117,5	8	2012	50		78		95	32		63	2,9
SPA 118 06	6	118	123,5	8	2012	50		84		95	32		63	3,3
SPA 125 06	6	125	130,5	3	2012	50		91		95	32	31,5	31,5	3,5
SPA 132 06	6	132	137,5	3	2517	65		98		95	45	25	25	3,8
SPA 140 06	6	140	145,5	3	2517	65		106		95	45	25	25	4,1
SPA 150 06	6	150	155,5	3	2517	65		116		95	45	25	25	4,9
SPA 160 06	6	160	165,5	3	2517	65		125		95	45	25	25	5,7
SPA 180 06	6	180	185,5	3	3020	75		146		95	51	22	22	8,5
SPA 200 06	6	200	205,5	3	3020	75		165		95	51	22	22	11,0
SPA 224 06	6	224	229,5	3	3020	75		189		95	51	22	22	13,4
SPA 236 06	6	236	241,5	3	3020	75		202		95	51	22	22	14,9
SPA 250 06	6	250	255,5	6	3020	75	155	215	20	95	51	22	22	16,4
SPA 280 06	6	280	285,5	5	3535	90	175	245		95	89	3	3	17,3
SPA 315 06	6	315	320,5	5	3535	90	175	280		95	89	3	3	19,5
SPA 355 06	6	355	360,5	5	3535	90	175	320		95	89	3	3	23,2
SPA 400 06	6	400	405,5	5	3535	90	175	365		95	89	3	3	22,4
SPA 450 06	6	450	455,5	5	3535	90	175	415		95	89	3	3	29,9
SPA 500 06	6	500	505,5	5	3535	90	175	465		95	89	3	3	30,4
SPA 560 06	6	560	565,5	5	3535	90	175	525		95	89	3	3	40,2
SPA 630 06	6	630	635,5	4	4040	100	210	595		95	102	3,5	3,5	48,0
SPA 800 06	6	800	805,5	4	4040	100	210	765		95	102	3,5	3,5	72,0
SPA1000 06	6	1000	1005,5	4	4545	110	242	965		95	114	9,5	9,5	97,0

Kileremskiver for taperbøsninger

SPB - 1

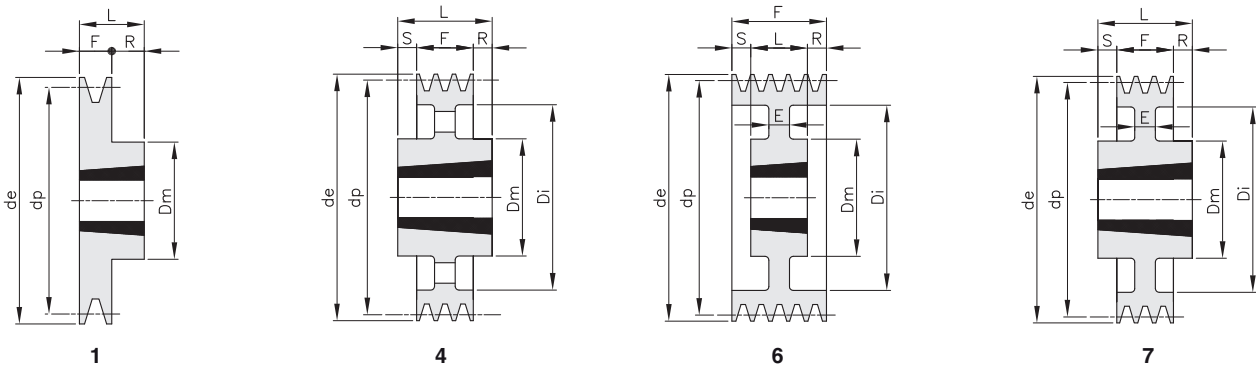

Materiale støbejern EN-GJL-200 / *Materiale stål

Betegnelse	Spor	dp	de	Type	Bøsning	Boring Max	Dm	Di	E	F	L	R	S	Kg.
SPB 100 01	1	100	107	1	1610	42				25	25			0,9
SPB 106 01	1	106	113	1	1610	42				25	25			1,0
SPB 112 01	1	112	119	1	1610	42				25	25			1,2
SPB 118 01	1	118	125	1	1610	42				25	25			1,3
SPB 125 01	1	125	132	1	1610	42				25	25			1,5
SPB 132 01	1	132	139	1	1610	42				25	25			1,7
SPB 140 01	1	140	147	1	1610	42				25	25			1,8
SPB 150 01	1	150	157	1	1610	42				25	25			2,1
SPB 160 01	1	160	167	1	1610	42				25	25			2,5
SPB 170 01	1	170	177	1	1610	42				25	25			2,9
SPB 180 01	1	180	187	6	1610	42	90	132	12	25	25			3,2
SPB 190 01	1	190	197	7	2012	50	104	147	12	25	32	3,5	3,5	3,8
SPB 200 01	1	200	207	4	2012	50	104	157		25	32	3,5	3,5	4,2
SPB 212 01	1	212	219	4	2012	50	104	169		25	32	3,5	3,5	4,4
SPB 224 01	1	224	231	4	2012	50	104	181		25	32	3,5	3,5	4,7
SPB 236 01	1	236	243	4	2012	50	104	193		25	32	3,5	3,5	4,6
SPB 250 01	1	250	257	4	2012	50	104	207		25	32	3,5	3,5	5,3
SPB 280 01	1	280	287	4	2012	50	104	237		25	32	3,5	3,5	6,0
SPB 300 01	1	300	307	4	2012	50	104	258		25	32	3,5	3,5	6,5
SPB 315 01	1	315	322	4	2012	50	104	272		25	32	3,5	3,5	7,0

Kileremskiver for taperbøsninger

SPB - 2

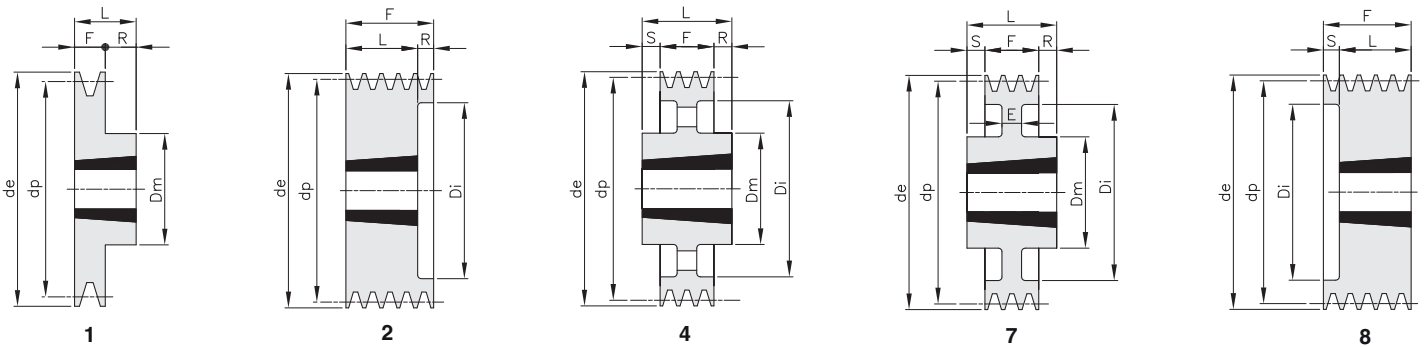

Materiale støbejern EN-GJL-200 / *Materiale stål

Betegnelse	Spor	dp	de	Type	Bøsning	Boring Max	Dm	Di	E	F	L	R	S	Kg.
SPB 100 02	2	100	107	8	1610	42		62		44	25		19	1,4
SPB 106 02	2	106	113	8	1610	42		67		44	25		19	1,6
SPB 112 02	2	112	119	8	1610	42		72		44	25		19	1,7
SPB 118 02	2	118	125	2	1610	42		78		44	25	19		1,8
SPB 125 02	2	125	132	2	2012	50		82		44	32	12		1,9
SPB 132 02	2	132	139	2	2012	50		89		44	32	12		2,5
SPB 140 02	2	140	147	2	2012	50		97		44	32	12		2,7
SPB 150 02	2	150	157	2	2012	50		107		44	32	12		3,2
SPB 160 02	2	160	167	2	2012	50		117		44	32	12		3,8
SPB 170 02	2	170	177	2	2012	50		127		44	32	12		4,8
SPB 180 02	2	180	187	1	2517	65	120			44	45	1		6,3
SPB 190 02	2	190	197	1	2517	65	120			44	45	1		7,2
SPB 200 02	2	200	207	1	2517	65	117			44	45	1		8,2
SPB 212 02	2	212	219	7	2517	65	117	169	15	44	45	1		5,4
SPB 224 02	2	224	231	4	2517	65	117	181		44	45	1		5,9
SPB 236 02	2	236	243	4	2517	65	117	193		44	45	1		6,6
SPB 250 02	2	250	257	4	2517	65	125	207		44	45	1		7,1
SPB 280 02	2	280	287	4	2517	65	125	237		44	45	1		7,4
SPB 300 02	2	300	307	4	2517	65	125	257		44	45	1		8,6
SPB 315 02	2	315	322	4	2517	65	125	272		44	45	1		9,9
SPB 335 02	2	335	342	4	2517	65	125	292		44	45	1		11,3
SPB 355 02	2	355	362	4	3020	75	144	312		44	51	3,5	3,5	12,0
SPB 400 02	2	400	407	4	3020	75	150	357		44	51	3,5	3,5	13,0
SPB 450 02	2	450	457	4	3020	75	150	407		44	51	3,5	3,5	13,5
SPB 500 02	2	500	507	4	3020	75	150	457		44	51	3,5	3,5	15,0
SPB 560 02	2	560	567	4	3030	75	150	517		44	76	28	4	17,0
SPB 630 02	2	630	637	4	3030	75	150	587		44	76	16	16	19,3

Kileremskiver for taperbøsninger

SPB - 3

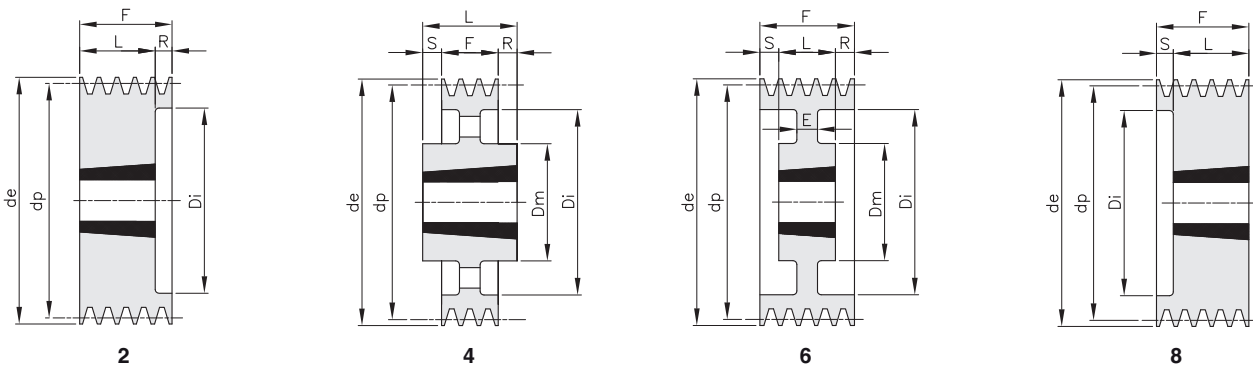

Materiale støbejern EN-GJL-200 / *Materiale stål

Betegnelse	Spor	dp	de	Type	Bøsning	Boring Max	Dm	Di	E	F	L	R	S	Kg.
SPB 100 03	3	100	107	8	1610	42		62		63	25		38	1,9
SPB 106 03	3	106	113	8	1610	42		67		63	25		38	2,2
SPB 112 03	3	112	119	8	1610	42		72		63	25		38	2,4
SPB 118 03	3	118	125	2	1610	42		78		63	25	38		2,6
SPB 125 03	3	125	132	2	2012	50		82		63	32	31		3,2
SPB 132 03	3	132	139	2	2012	50		89		63	32	31		3,2
SPB 140 03	3	140	147	2	2012	50		97		63	32	31		3,6
SPB 150 03	3	150	157	2	2517	65		107		63	45	18		4,0
SPB 160 03	3	160	167	2	2517	65		117		63	45	18		4,5
SPB 170 03	3	170	177	2	2517	65		127		63	45	18		5,3
SPB 180 03	3	180	187	2	2517	65		137		63	45	18		5,9
SPB 190 03	3	190	197	2	2517	65		147		63	45	18		6,5
SPB 200 03	3	200	207	2	2517	65		157		63	45	18		6,7
SPB 212 03	3	212	219	6	2517	65	117	169	15	63	45	18		6,9
SPB 224 03	3	224	231	4	2517	65	117	181		63	45	18		7,5
SPB 236 03	3	236	243	4	2517	65	117	193		63	45	18		8,8
SPB 250 03	3	250	257	4	3020	75	144	207		63	51	12		10,2
SPB 280 03	3	280	287	4	3020	75	144	237		63	51	6	6	11,3
SPB 300 03	3	300	307	4	3020	75	144	257		63	51	6	6	12,3
SPB 315 03	3	315	322	4	3020	75	144	272		63	51	6	6	13,5
SPB 335 03	3	335	342	4	3020	75	144	292		63	51	6	6	14,7
SPB 355 03	3	355	362	4	3020	75	144	312		63	51	6	6	15,9
SPB 400 03	3	400	407	4	3535	90	175	357		63	89	13	13	18,8
SPB 450 03	3	450	457	4	3535	90	175	407		63	89	26		22,5
SPB 500 03	3	500	507	4	3535	90	175	457		63	89	26		24,0
SPB 560 03	3	560	567	4	3535	90	175	517		63	89	26		30,0
SPB 630 03	3	630	637	4	3535	90	175	587		63	89	26		33,5
SPB 710 03	3	710	717	4	3535	90	175	664		63	89	13	13	35,0
SPB 800 03	3	800	807	4	3535	90	175	754		63	89	13	13	38,0
SPB 900 03	3	900	907	4	3535	90	175	854		63	89	13	13	48,0
SPB1000 03	3	1000	1007	4	4040	100	210	954		63	102	19,5	19,5	55,0
SPB1250 03	3	1250	1257	4	4040	100	210	1204		63	102	19,5	19,5	100,0

Kileremskiver for taperbøsninger

SPB - 4

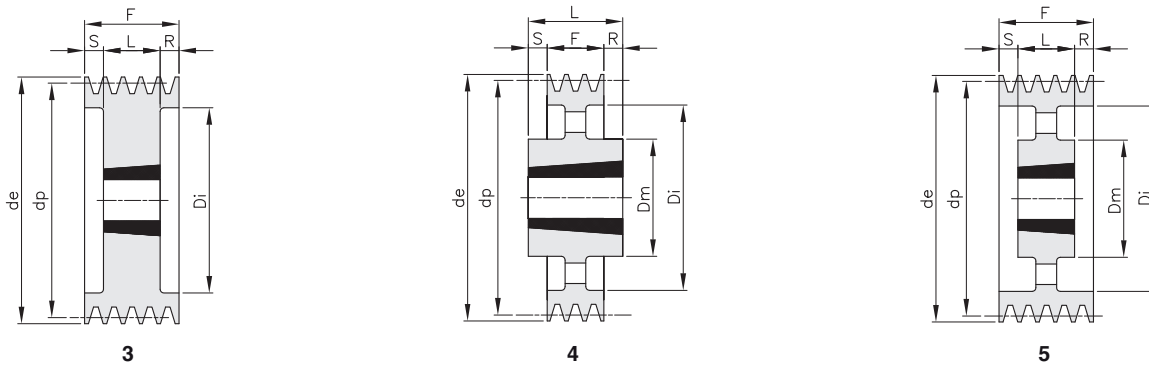

Materiale støbejern EN-GJL-200 / *Materiale stål

Betegnelse	Spor	dp	de	Type	Bøsning	Boring Max	Dm	Di	E	F	L	R	S	Kg.
SPB 125 04	4	125	132	3	2012	50		82		82	32	25	25	3,5
SPB 132 04	4	132	139	3	2012	50		89		82	32	25	25	3,7
SPB 140 04	4	140	147	3	2517	65		100		82	45	18,5	18,5	4,3
SPB 150 04	4	150	157	3	2517	65		107		82	45	18,5	18,5	4,6
SPB 160 04	4	160	167	3	2517	65		117		82	45	18,5	18,5	5,2
SPB 170 04	4	170	177	3	2517	65		127		82	45	18,5	18,5	6,1
SPB 180 04	4	180	187	3	2517	65		137		82	45	18,5	18,5	7,2
SPB 190 04	4	190	197	3	2517	65		147		82	45	18,5	18,5	7,9
SPB 200 04	4	200	207	3	3020	75		157		82	51	15,5	15,5	9,1
SPB 212 04	4	212	219	3	3020	75		169		82	51	15,5	15,5	10,0
SPB 224 04	4	224	231	3	3020	75		181		82	51	15,5	15,5	11,5
SPB 236 04	4	236	243	3	3020	75		193		82	51	15,5	15,5	12,8
SPB 250 04	4	250	257	5	3020	75	144	207		82	51	15,5	15,5	13,5
SPB 280 04	4	280	287	5	3020	75	144	237		82	51	15,5	15,5	14,1
SPB 300 04	4	300	307	4	3535	90	175	257		82	89	7		15,8
SPB 315 04	4	315	322	4	3535	90	175	272		82	89	3,5	3,5	17,5
SPB 335 04	4	335	342	4	3535	90	175	292		82	89	3,5	3,5	18,4
SPB 355 04	4	355	362	4	3535	90	175	312		82	89	3,5	3,5	19,2
SPB 400 04	4	400	407	4	3535	90	175	357		82	89	3,5	3,5	21,0
SPB 450 04	4	450	457	4	3535	90	175	407		82	89	7		25,0
SPB 500 04	4	500	507	4	3535	90	175	457		82	89	7		27,0
SPB 560 04	4	560	567	4	3535	90	175	517		82	89	7		33,2
SPB 630 04	4	630	637	4	3535	90	175	587		82	89	7		36,0
SPB 710 04	4	710	717	4	3535	90	175	664		82	89	3,5	3,5	42,0
SPB 800 04	4	800	807	4	4040	100	210	754		82	102	10	10	53,5
SPB 900 04	4	900	907	4	4040	100	210	854		82	102	10	10	62,0
SPB1000 04	4	1000	1007	4	4040	100	210	954		82	102	16	10	68,0
SPB1250 04	4	1250	1257	4	4545	110	242	1204		82	114	16	16	114,5

Kileremskiver for taperbøsninger

SPB - 5

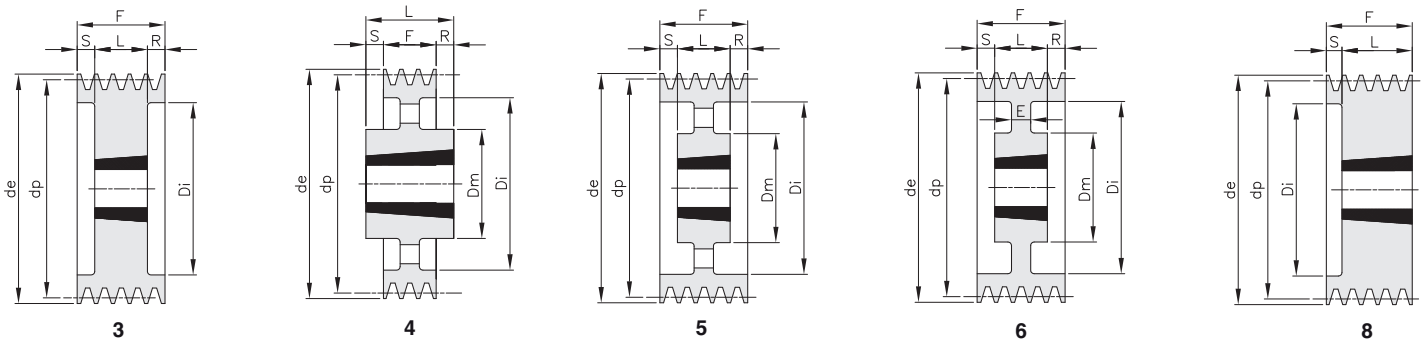

Materiale støbejern EN-GJL-200 / *Materiale stål

Betegnelse	Spor	dp	de	Type	Bøsning	Boring Max	Dm	Di	E	F	L	R	S	Kg.
SPB 125 05	5	125	132	8	2012	50		87		101	32		69	4,2
SPB 132 05	5	132	139	8	2517	65		94		101	45		56	4,4
SPB 140 05	5	140	147	3	2517	65		97		101	45	28	28	4,8
SPB 150 05	5	150	157	3	2517	65		107		101	45	28	28	5,4
SPB 160 05	5	160	167	3	2517	65		117		101	45	28	28	6,2
SPB 170 05	5	170	177	3	3020	75		127		101	51	25	25	7,1
SPB 180 05	5	180	187	3	3020	75		137		101	51	25	25	7,5
SPB 190 05	5	190	197	3	3020	75		147		101	51	25	25	8,5
SPB 200 05	5	200	207	3	3020	75		157		101	51	25	25	9,6
SPB 212 05	5	212	219	3	3020	75		169		101	51	25	25	11,5
SPB 224 05	5	224	231	3	3020	75		181		101	51	25	25	13,0
SPB 236 05	5	236	243	3	3535	90		193		101	89	6	6	16,2
SPB 250 05	5	250	257	3	3535	90		207		101	89	6	6	17,2
SPB 280 05	5	280	287	6	3535	90	175	237	25	101	89	6	6	18,5
SPB 300 05	5	300	307	5	3535	90	175	257		101	89	6	6	19,0
SPB 315 05	5	315	322	5	3535	90	175	272		101	89	6	6	19,5
SPB 335 05	5	335	342	5	3535	90	175	292		101	89	6	6	20,4
SPB 355 05	5	355	362	4	3535	90	175	312		101	89	6	6	21,5
SPB 400 05	5	400	407	4	3535	90	175	357		101	89	6	6	24,5
SPB 450 05	5	450	457	4	3535	90	175	407		101	89	12		29,0
SPB 500 05	5	500	507	4	3535	90	175	457		101	89	12		31,5
SPB 560 05	5	560	567	4	4040	100	210	517		101	102	1		36,0
SPB 630 05	5	630	637	4	4040	100	210	587		101	102	1		48,5
SPB 710 05	5	710	717	4	4040	100	210	664		101	102	1		52,0
SPB 800 05	5	800	807	4	4040	100	210	754		101	102	1		56,2
SPB 900 05	5	900	907	4	4040	100	210	854		101	102	1		76,0
SPB1000 05	5	1000	1007	4	4545	110	242	954		101	114	6,5	6,5	85,3
SPB1250 05	5	1250	1257	4	4545	110	242	1204		101	114	6,5	6,5	150,7

Kileremskiver for taperbøsninger

SPB - 6

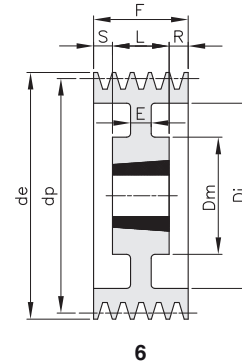
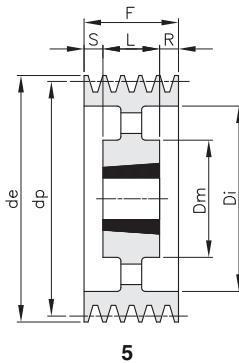
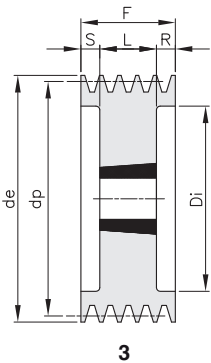

Materiale støbejern EN-GJL-200 / *Materiale stål

Betegnelse	Spor	dp	de	Type	Bøsning	Boring Max	Dm	Di	E	F	L	R	S	Kg.
SPB 140 06	6	140	147	3	2517	65		100		120	45	37,5	37,5	5,8
SPB 150 06	6	150	157	3	2517	65		107		120	45	37,5	37,5	6,8
SPB 160 06	6	160	167	3	3020	75		118		120	51	34,5	34,5	6,9
SPB 170 06	6	170	177	3	3020	75		127		120	51	34,5	34,5	8,1
SPB 180 06	6	180	187	3	3020	75		137		120	51	34,5	34,5	8,2
SPB 190 06	6	190	197	3	3020	75		147		120	51	34,5	34,5	9,4
SPB 200 06	6	200	207	3	3020	75		157		120	51	34,5	34,5	10,5
SPB 212 06	6	212	219	3	3535	90		169		120	89	15,5	15,5	14,5
SPB 224 06	6	224	231	3	3535	90		181		120	89	15,5	15,5	17,5
SPB 236 06	6	236	243	3	3535	90		193		120	89	15,5	15,5	20,0
SPB 250 06	6	250	257	3	3535	90		207		120	89	15,5	15,5	21,5
SPB 280 06	6	280	287	6	3535	90	175	237	25	120	89	15,5	15,5	22,1
SPB 300 06	6	300	307	5	3535	90	175	257		120	89	15,5	15,5	23,5
SPB 315 06	6	315	322	5	3535	90	175	272		120	89	15,5	15,5	24,6
SPB 335 06	6	335	342	5	3535	90	175	292		120	89	15,5	15,5	26,3
SPB 355 06	6	355	362	5	3535	90	175	312		120	89	15,5	15,5	28,4
SPB 400 06	6	400	407	5	3535	90	175	357		120	89	15,5	15,5	32,9
SPB 450 06	6	450	457	5	4040	100	210	407		120	102	18		36,5
SPB 500 06	6	500	507	5	4040	100	210	457		120	102	18		40,0
SPB 560 06	6	560	567	5	4040	100	210	517		120	102	18		47,5
SPB 630 06	6	630	637	5	4040	100	210	587		120	102	18		55,0
SPB 710 06	6	710	717	5	4040	100	210	664		120	102	9	9	62,5
SPB 800 06	6	800	807	5	4545	110	242	754		120	114	3	3	71,0
SPB 900 06	6	900	907	5	4545	110	242	854		120	114	3	3	83,7
SPB1000 06	6	1000	1007	5	4545	110	242	954		120	114	3	3	100,4
SPB1250 06	6	1250	1257	5	4545	110	242	1204		120	114	3	3	136,0

Kileremskiver for taperbøsninger

SPB - 8

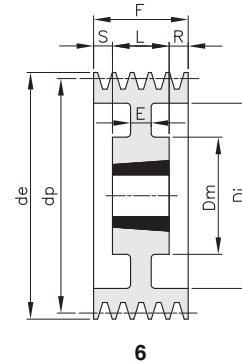
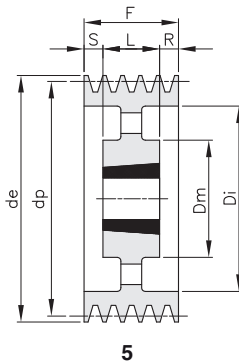
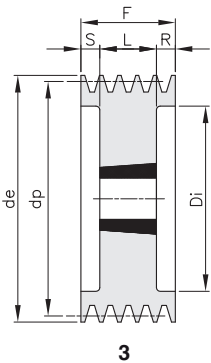

Materiale støbejern EN-GJL-200 / *Materiale stål

Betegnelse	Spor	dp	de	Type	Bøsning	Boring Max	Dm	Di	E	F	L	R	S	Kg.
SPB 140 08	8	140	147	3	2517	65		97		158	45	56,5	56,5	7,0
SPB 160 08	8	160	167	3	3020	75		118		158	51	53,5	53,5	11,6
SPB 170 08	8	170	177	3	3030	75		127		158	76	41	41	12,5
SPB 180 08	8	180	187	3	3030	75		137		158	76	41	41	13,7
SPB 190 08	8	190	197	3	3030	75		147		158	76	41	41	15,6
SPB 200 08	8	200	207	3	3535	90		157		158	89	34,5	34,5	17,6
SPB 212 08	8	212	219	3	3535	90		169		158	89	34,5	34,5	20,5
SPB 224 08	8	224	231	3	3535	90		181		158	89	34,5	34,5	22,5
SPB 236 08	8	236	243	3	3535	90		193		158	89	34,5	34,5	24,0
SPB 250 08	8	250	257	3	3535	90		207		158	89	34,5	34,5	26,5
SPB 280 08	8	280	287	6	3535	90	175	237	25	158	89	34,5	34,5	28,0
SPB 300 08	8	300	307	6	3535	90	175	257	25	158	89	34,5	34,5	30,1
SPB 315 08	8	315	322	5	3535	90	175	272		158	89	34,5	34,5	31,2
SPB 335 08	8	335	342	5	3535	90	175	292		158	89	34,5	34,5	33,5
SPB 355 08	8	355	362	5	3535	90	175	312		158	89	34,5	34,5	35,7
SPB 400 08	8	400	407	5	4040	100	210	357		158	102	28	28	37,0
SPB 450 08	8	450	457	5	4040	100	210	407		158	102	28	28	42,0
SPB 500 08	8	500	507	5	4040	100	210	457		158	102	28	28	46,5
SPB 560 08	8	560	567	5	4545	110	242	517		158	114	22	22	58,0
SPB 630 08	8	630	637	5	4545	110	242	587		158	114	22	22	64,0
SPB 710 08	8	710	717	5	4545	110	242	664		158	114	22	22	72,8
SPB 800 08	8	800	807	5	4545	110	242	754		158	114	22	22	92,0
SPB 900 08	8	900	907	5	4545	110	242	854		158	114	22	22	115,0
SPB1000 08	8	1000	1007	5	5050	125	267	954		158	127	15,5	15,5	140,0
SPB1250 08	8	1250	1257	5	5050	125	267	1204		158	127	15,5	15,5	204,0

Kileremskiver for taperbøsninger

SPB - 10

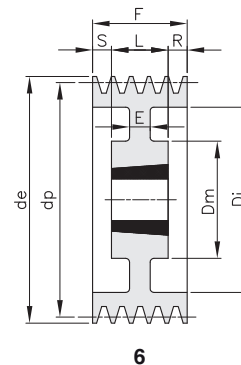
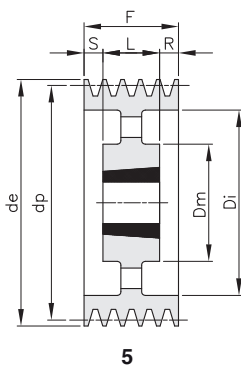
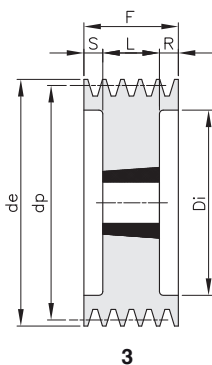

Materiale støbejern EN-GJL-200 / *Materiale stål

Betegnelse	Spor	dp	de	Type	Bøsning	Boring Max	Dm	Di	E	F	L	R	S	Kg.
SPB 224 10	10	224	231	3	3535	90		181		196	89	53,5	53,5	22,5
SPB 236 10	10	236	243	3	3535	90		193		196	89	53,5	53,5	25,0
SPB 250 10	10	250	257	3	3535	90		207		196	89	53,5	53,5	29,0
SPB 280 10	10	280	287	6	3535	90	175	237	30	196	89	53,5	53,5	31,5
SPB 315 10	10	315	322	6	3535	90	175	272	30	196	89	53,5	53,5	35,0
SPB 335 10	10	335	342	5	4040	100	210	292		196	102	47	47	37,0
SPB 355 10	10	355	362	5	4040	100	210	312		196	102	47	47	38,5
SPB 400 10	10	400	407	5	4040	100	210	357		196	102	47	47	40,5
SPB 450 10	10	450	457	5	4545	110	242	407		196	114	41	41	53,5
SPB 500 10	10	500	507	5	4545	110	242	457		196	114	41	41	58,0
SPB 560 10	10	560	567	5	4545	110	242	517		196	114	41	41	64,7
SPB 630 10	10	630	637	5	4545	110	242	587		196	114	41	41	72,0
SPB 710 10	10	710	717	5	4545	110	242	664		196	114	41	41	82,4
SPB 800 10	10	800	807	5	4545	110	242	754		196	114	41	41	103,0
SPB 900 10	10	900	907	5	5050	125	267	854		196	127	34,5	34,5	131,5
SPB1000 10	10	1000	1007	5	5050	125	267	954		196	127	34,5	34,5	153,0

Kileremskiver for taperbøsninger

SPC - 3

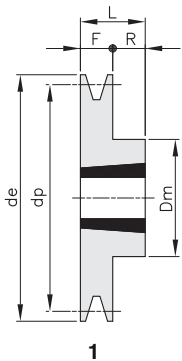

1

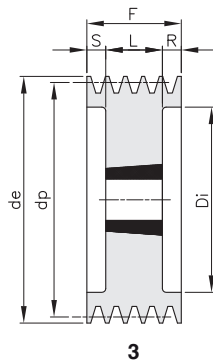

3

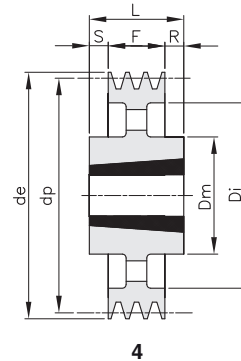

4

Materiale støbejern EN-GJL-200 / *Materiale stål

Betegnelse	Spor	dp	de	Type	Bøsning	Boring Max	Dm	Di	E	F	L	R	S	Kg.
SPC 200 03	3	200	209,6	3	2517	65		144		85	45	20	20	10,2
SPC 212 03	3	212	221,6	3	3020	75		156		85	51	17	17	11,0
SPC 224 03	3	224	233,6	3	3020	75		168		85	51	17	17	12,0
SPC 236 03	3	236	245,6	3	3020	75		180		85	51	17	17	13,0
SPC 250 03	3	250	259,6	3	3020	75		194		85	51	17	17	15,5
SPC 265 03	3	265	274,6	1	3535	90	175			85	89	4		17,2
SPC 280 03	3	280	289,6	1	3535	90	175			85	89	4		19,4
SPC 300 03	3	300	309,6	4	3535	90	175	244		85	89	2	2	22,6
SPC 315 03	3	315	324,6	4	3535	90	175	259		85	89	2	2	22,5
SPC 335 03	3	335	344,6	4	3535	90	175	279		85	89	2	2	23,5
SPC 355 03	3	355	364,6	4	3535	90	175	299		85	89	2	2	24,8
SPC 375 03	3	375	384,6	4	3535	90	175	319		85	89	2	2	25,5
SPC 400 03	3	400	409,6	4	3535	90	175	344		85	89	2	2	26,4
SPC 425 03	3	425	434,6	4	3535	90	175	369		85	89	2	2	27,0
SPC 450 03	3	450	459,6	4	3535	90	175	394		85	89	2	2	28,6
SPC 475 03	3	475	484,6	4	3535	90	175	419		85	89	2	2	30,0
SPC 500 03	3	500	509,6	4	3535	90	175	444		85	89	2	2	31,9
SPC 530 03	3	530	539,6	4	3535	90	175	474		85	89	2	2	34,5
SPC 560 03	3	560	569,6	4	3535	90	175	504		85	89	2	2	37,0
SPC 630 03	3	630	639,6	4	4040	100	210	574		85	102	8,5	8,5	44,5
SPC 800 03	3	800	809,6	4	4545	110	242	737		85	114	14,5	14,5	65,0
SPC1000 03	3	1000	1009,6	4	5050	125	267	937		85	127	21	21	93,0
SPC1250 03	3	1250	1259,6	4	5050	125	267	1187		85	127	21	21	101,0

Kileremskiver for taperbøsninger

SPC - 4

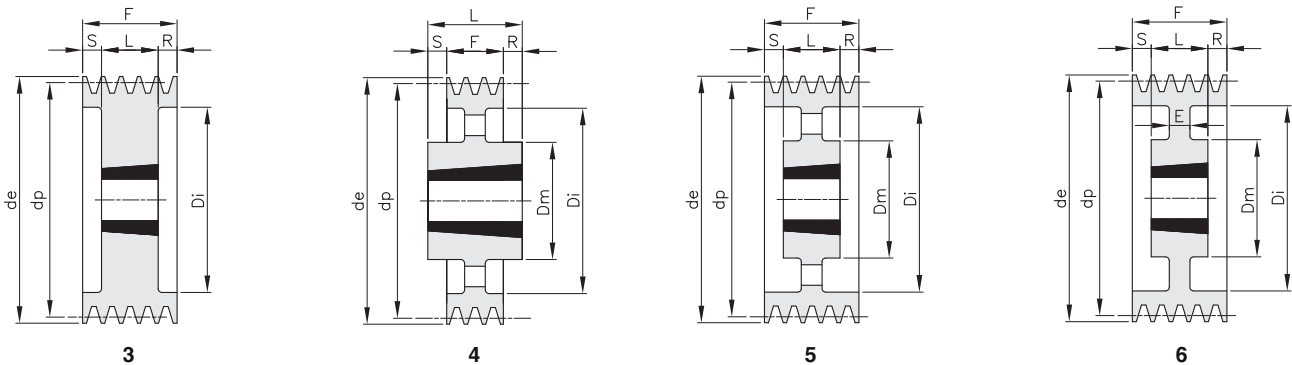

Materiale støbejern EN-GJL-200 / *Materiale stål

Betegnelse	Spor	dp	de	Type	Bøsning	Boring Max	Dm	Di	E	F	L	R	S	Kg.
SPC 200 04	4	200	209,6	3	3020	75		144		111	51	30	30	12,5
SPC 212 04	4	212	221,6	3	3020	75		156		111	51	30	30	13,5
SPC 224 04	4	224	233,6	3	3535	90		168		111	89	11	11	15,0
SPC 236 04	4	236	245,6	3	3535	90		180		111	89	11	11	18,2
SPC 250 04	4	250	259,6	3	3535	90		194		111	89	11	11	21,7
SPC 265 04	4	265	274,6	3	3535	90		209		111	89	11	11	23,0
SPC 280 04	4	280	289,6	6	3535	90	175	224	18	111	89	11	11	24,1
SPC 300 04	4	300	309,6	6	3535	90	175	244	20	111	89	11	11	25,0
SPC 315 04	4	315	324,6	5	3535	90	175	259		111	89	11	11	26,4
SPC 335 04	4	335	344,6	5	3535	90	175	279		111	89	11	11	27,5
SPC 355 04	4	355	364,6	5	3535	90	175	299		111	89	11	11	29,3
SPC 375 04	4	375	384,6	5	3535	90	175	319		111	89	11	11	31,0
SPC 400 04	4	400	409,6	5	3535	90	175	344		111	89	11	11	32,8
SPC 425 04	4	425	434,6	5	3535	90	175	369		111	89	11	11	33,4
SPC 450 04	4	450	459,6	5	3535	90	175	394		111	89	11	11	36,8
SPC 475 04	4	475	484,6	5	3535	90	175	419		111	89	11	11	38,0
SPC 500 04	4	500	509,6	5	3535	90	175	444		111	89	11	11	40,0
SPC 530 04	4	530	539,6	5	4040	100	210	474		111	102	4,5	4,5	45,0
SPC 560 04	4	560	569,6	5	4040	100	210	504		111	102	4,5	4,5	50,0
SPC 630 04	4	630	639,6	4	4545	110	242	574		111	114	1,5	1,5	58,0
SPC 710 04	4	710	719,6	4	5050	125	267	654		111	127	8	8	64,0
SPC 800 04	4	800	809,6	4	5050	125	267	737		111	127	8	8	76,5
SPC1000 04	4	1000	1009,6	4	5050	125	267	937		111	127	8	8	105,0
SPC1250 04	4	1250	1259,6	4	5050	125	267	1187		111	127	8	8	178,0

Kileremskiver for taperbøsninger

SPC - 5

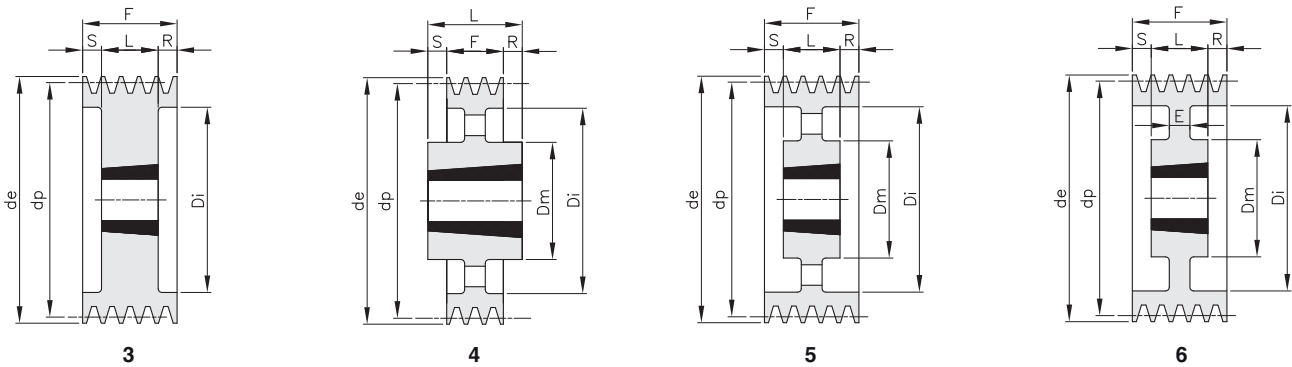

Materiale støbejern EN-GJL-200 / *Materiale stål

Betegnelse	Spor	dp	de	Type	Bøsning	Boring Max	Dm	Di	E	F	L	R	S	Kg.
SPC 200 05	5	200	209,6	3	3535	90		144		136	89	23,5	23,5	14,7
SPC 212 05	5	212	221,6	3	3535	90		156		136	89	23,5	23,5	15,0
SPC 224 05	5	224	233,6	3	3535	90		168		136	89	23,5	23,5	17,2
SPC 236 05	5	236	245,6	3	3535	90		180		136	89	23,5	23,5	20,2
SPC 250 05	5	250	259,6	3	3535	90		194		136	89	23,5	23,5	23,5
SPC 265 05	5	265	274,6	3	3535	90		209		136	89	23,5	23,5	25,5
SPC 280 05	5	280	289,6	3	3535	90		224		136	89	23,5	23,5	27,2
SPC 300 05	5	300	309,6	6	3535	90	175	244	20	136	89	23,5	23,5	28,5
SPC 315 05	5	315	324,6	5	3535	90	175	259		136	89	23,5	23,5	29,5
SPC 335 05	5	335	344,6	5	3535	90	175	279		136	89	23,5	23,5	31,0
SPC 355 05	5	355	364,6	5	3535	90	175	299		136	89	23,5	23,5	33,5
SPC 375 05	5	375	384,6	5	3535	90	175	319		136	89	23,5	23,5	36,0
SPC 400 05	5	400	409,6	5	3535	90	175	344		136	89	23,5	23,5	37,0
SPC 425 05	5	425	434,6	5	3535	90	175	369		136	89	23,5	23,5	43,0
SPC 450 05	5	450	459,6	5	4040	100	210	394		136	102	17	17	46,0
SPC 475 05	5	475	484,6	5	4040	100	210	419		136	102	17	17	50,3
SPC 500 05	5	500	509,6	5	4040	100	210	444		136	102	17	17	54,0
SPC 530 05	5	530	539,6	5	4545	110	240	474		136	114	11	11	57,5
SPC 560 05	5	560	569,6	5	4545	110	242	504		136	114	11	11	61,0
SPC 630 05	5	630	639,6	5	5050	125	267	574		136	127	4,5	4,5	75,0
SPC 710 05	5	710	719,6	5	5050	125	267	654		136	127	4,5	4,5	79,0
SPC 800 05	5	800	809,6	5	5050	125	267	737		136	127	4,5	4,5	96,5
SPC1000 05	5	1000	1009,6	5	5050	125	267	937		136	127	4,5	4,5	139,0
SPC1250 05	5	1250	1259,6	5	5050	125	267	1187		136	127	4,5	4,5	196,0

Kileremskiver for taperbøsninger

SPC - 6

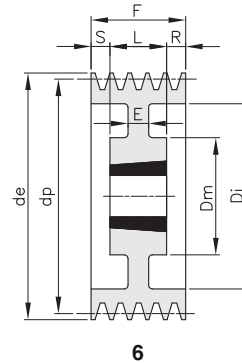
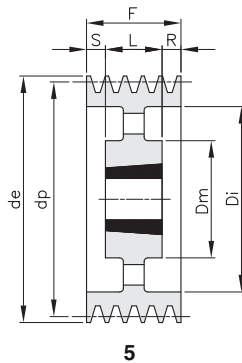
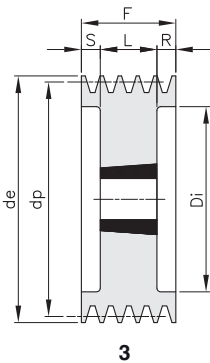

Materiale støbejern EN-GJL-200 / *Materiale stål

Betegnelse	Spor	dp	de	Type	Bøsning	Boring Max	Dm	Di	E	F	L	R	S	Kg.
SPC 200 06	6	200	209,6	3	3535	90		144		162	89	36,5	36,5	17,5
SPC 212 06	6	212	221,6	3	3535	90		156		162	89	36,5	36,5	19,0
SPC 224 06	6	224	233,6	3	3535	90		168		162	89	36,5	36,5	21,0
SPC 236 06	6	236	245,6	3	3535	90		180		162	89	36,5	36,5	23,0
SPC 250 06	6	250	259,6	3	3535	90		194		162	89	36,5	36,5	26,0
SPC 265 06	6	265	274,6	3	3535	90		209		162	89	36,5	36,5	27,0
SPC 280 06	6	280	289,6	6	3535	90	175	224	20	162	89	36,5	36,5	29,0
SPC 300 06	6	300	309,6	6	3535	90	175	244	20	162	89	36,5	36,5	31,5
SPC 315 06	6	315	324,6	5	3535	90	175	259		162	89	36,5	36,5	33,2
SPC 335 06	6	335	344,6	5	3535	90	175	279		162	89	36,5	36,5	35,0
SPC 355 06	6	355	364,6	5	3535	90	175	299		162	89	36,5	36,5	37,0
SPC 375 06	6	375	384,6	5	4040	100	210	319		162	102	30	30	42,5
SPC 400 06	6	400	409,6	5	4040	100	210	344		162	102	30	30	47,5
SPC 425 06	6	425	434,6	5	4040	100	210	369		162	102	30	30	55,6
SPC 450 06	6	450	459,6	5	4545	110	242	394		162	114	24	24	62,5
SPC 475 06	6	475	484,6	5	4545	110	242	419		162	114	24	24	65,0
SPC 500 06	6	500	509,6	5	4545	110	242	444		162	114	24	24	68,2
SPC 530 06	6	530	539,6	5	5050	125	265	474		162	127	17,5	17,5	73,0
SPC 560 06	6	560	569,6	5	5050	125	267	504		162	127	17,5	17,5	86,0
SPC 630 06	6	630	639,6	5	5050	125	267	574		162	127	17,5	17,5	96,0
SPC 710 06	6	710	719,6	5	5050	125	267	654		162	127	17,5	17,5	102,0
SPC 800 06	6	800	809,6	5	5050	125	267	737		162	127	17,5	17,5	120,0
SPC1000 06	6	1000	1009,6	5	5050	125	267	937		162	127	17,5	17,5	160,0
SPC1250 06	6	1250	1259,6	5	5050	125	267	1187		162	127	17,5	17,5	232,7

Kileremskiver for taperbøsninger

SPC - 8

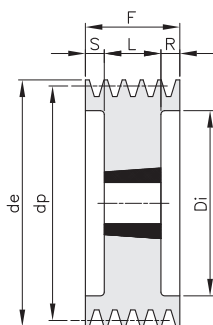

3

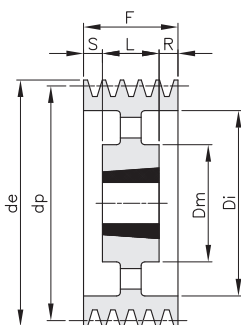

5

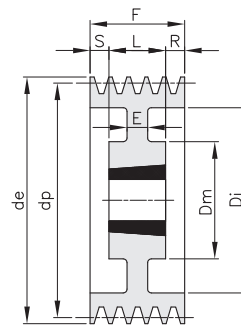

6

Materiale støbejern EN-GJL-200 / *Materiale stål

Betegnelse	Spor	dp	de	Type	Bøsning	Boring Max	Dm	Di	E	F	L	R	S	Kg.
SPC 200 08	8	200	209,6	3	3535	90		144		213	89	62	62	17,9
SPC 212 08	8	212	221,6	3	3535	90		156		213	89	62	62	24,0
SPC 224 08	8	224	233,6	3	3535	90		168		213	89	62	62	25,0
SPC 236 08	8	236	245,6	3	3535	90		180		213	89	62	62	27,0
SPC 250 08	8	250	259,6	3	3535	90		194		213	89	62	62	30,5
SPC 265 08	8	265	274,6	3	3535	90		209		213	89	62	62	34,5
SPC 280 08	8	280	289,6	3	3535	90		224		213	89	62	62	38,5
SPC 300 08	8	300	309,6	3	4040	100		244		213	102	55,5	55,5	47,5
SPC 315 08	8	315	324,6	3	4040	100		259		213	102	55,5	55,5	51,0
SPC 335 08	8	335	344,6	6	4040	100	210	279	50	213	102	55,5	55,5	44,5
SPC 355 08	8	355	364,6	5	4040	100	210	299		213	102	55,5	55,5	57,0
SPC 375 08	8	375	384,6	5	4545	110	242	319		213	114	49,5	49,5	62,0
SPC 400 08	8	400	409,6	5	4545	110	242	344		213	114	49,5	49,5	66,5
SPC 425 08	8	425	434,6	5	4545	110	242	369		213	114	49,5	49,5	75,0
SPC 450 08	8	450	459,6	5	5050	125	267	394		213	127	43	43	80,5
SPC 475 08	8	475	484,6	5	5050	125	267	419		213	127	43	43	85,5
SPC 500 08	8	500	509,6	5	5050	125	267	444		213	127	43	43	90,2
SPC 530 08	8	530	539,6	5	5050	125	267	474		213	127	43	43	92,5
SPC 560 08	8	560	569,6	5	5050	125	267	504		213	127	43	43	109,0
SPC 630 08	8	630	639,6	5	5050	125	267	574		213	127	43	43	120,2
SPC 710 08	8	710	719,6	5	5050	125	267	654		213	127	43	43	124,7
SPC 800 08	8	800	809,6	5	5050	125	267	737		213	127	43	43	148,0
SPC1000 08	8	1000	1009,6	5	5050	125	267	937		213	127	43	43	188,2
SPC1250 08	8	1250	1259,6	5	5050	125	267	1187		213	127	43	43	260,0

Kileremskiver for taperbøsninger

SPC - 10

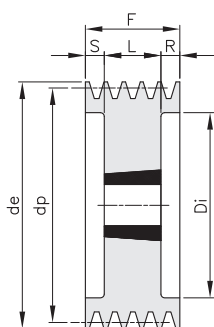

3

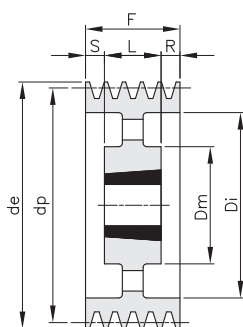

5

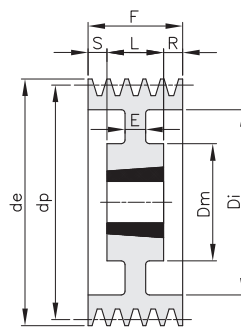

6

Materiale støbejern EN-GJL-200 / *Materiale stål

Betegnelse	Spor	dp	de	Type	Bøsning	Boring Max	Dm	Di	E	F	L	R	S	Kg.
SPC 250 10	10	250	259,6	3	4040	100		194		264	102	81	81	39,6
SPC 280 10	10	280	289,6	3	4040	100		224		264	102	81	81	51,4
SPC 300 10	10	300	309,6	3	4545	110		244		264	114	75	75	57,9
SPC 315 10	10	315	324,6	3	4545	110		259		264	114	75	75	72,0
SPC 335 10	10	335	344,6	3	4545	110		279		264	114	75	75	76,5
SPC 355 10	10	355	364,6	3	4545	110		299		264	114	75	75	83,4
SPC 400 10	10	400	409,6	6	5050	125	267	344	70	264	127	68,5	68,5	80,5
SPC 450 10	10	450	459,6	5	5050	125	267	394		264	127	68,5	68,5	100,9
SPC 500 10	10	500	509,6	5	5050	125	267	444		264	127	68,5	68,5	114,0
SPC 560 10	10	560	569,6	5	5050	125	267	504		264	127	68,5	68,5	125,0
SPC 630 10	10	630	639,6	5	5050	125	267	574		264	127	68,5	68,5	145,0
SPC 710 10	10	710	719,6	5	5050	125	267	654		264	127	68,5	68,5	165,0
SPC 800 10	10	800	809,6	5	5050	125	267	737		264	127	68,5	68,5	182,0
SPC1000 10	10	1000	1009,6	5	5050	125	267	937		264	127	68,5	68,5	240,0
SPC1250 10	10	1250	1259,6	5	5050	125	267	1187		264	127	68,5	68,5	280,0
